



Specification for 2.9 inch EPD

Model NO. : OKRA0290RYF661F6

OKRA's Confirmation:

| Prepared by | Checked by | Approved by |
|-------------|------------|-------------|
| | | |

Customer approval:

| Customer | Approved by | Date |
|----------|-------------|------|
| | | |



Revision History

| Version | Content | Date | Producer |
|----------------|----------------|-------------|-----------------|
| 2.0 | New release | 2023/08/04 | |
| | | | |
| | | | |
| | | | |
| | | | |
| | | | |
| | | | |



CONTENTS

| | |
|---|----|
| 1. Over View | 4 |
| 2. Features | 4 |
| 3. Mechanical and Optical Specification | 5 |
| 4. Mechanical Drawing of EPD Module..... | 6 |
| 5. Input/output Pin Assignment..... | 7 |
| 6. Electrical Characteristics..... | 8 |
| 6.1 Absolute Maximum Rating | 8 |
| 6.2 Panel DC Characteristics..... | 9 |
| 6.3 Panel AC Characteristics..... | 10 |
| 6.3.1 MCU Interface Selection..... | 10 |
| 6.3.2 MCU Serial Interface (4-wire SPI) | 10 |
| 6.3.3 MCU Serial Interface (3-wire SPI) | 11 |
| 6.3.4 Interface Timing..... | 11 |
| 7.Command Table | 13 |
| 8. Block Diagram | 47 |
| 9. Typical Application Circuit with SPI Interface | 48 |
| 10 Typical Operating Sequence..... | 49 |
| 10.1 LUT from OTP Operation Flow..... | 49 |
| 10.2 OTP Operation Reference Program Code | 50 |
| 11. Reliability Test | 51 |
| 12.Quality Assurance | 52 |
| 12.1 Environment..... | 52 |
| 12.2 Illuminance..... | 52 |
| 12.3 Inspect method | 52 |
| 12.4 Display are | 52 |
| 12.5 Ghosting test method..... | 52 |
| 12.6 Inspection standard..... | 53 |
| 12.6.1 Electric inspection standard | 53 |
| 12.6.2 Appearance inspection standard..... | 54 |
| 13.Packaging | 56 |
| 14.Handling, Safety, and Environment Requirements | 57 |



1. Over View

OKRA0290RYF661F6 is an Active Matrix EPD all-in-one driver with timing controller for ESL. The sources have 2-bit outputs per pixel to support white/black/red/yellow. The 2.9 inch active area contains 296×128 pixels. The module is a TFT-array driving electrophoresis display, with integrated circuits including gate driver, source driver, MCU interface, timing controller, oscillator, DC-DC, SRAM, LUT, VCOM. Module can be used in portable electronic devices, such as Electronic Shelf Label (ESL) System.

2. Features

- ◆ 296×128 pixels display
- ◆ High contrast High reflectance
- ◆ Ultra wide viewing angle Ultra low power consumption
- ◆ Pure reflective mode
- ◆ Bi-stable display
- ◆ Commercial temperature range
- ◆ Landscape portrait modes
- ◆ Hard-coat antiglare display surface
- ◆ Ultra Low current deep sleep mode
- ◆ On chip display RAM
- ◆ Waveform can stored in On-chip OTP or written by MCU
- ◆ Serial peripheral interface available
- ◆ On-chip oscillator
- ◆ On-chip booster and regulator control for generating VCOM, Gate and Source driving voltage
- ◆ I²C signal master interface to read external temperature sensor
- ◆ Built-in temperature sensor



3. Mechanical and Optical Specification

| Parameter | Specifications | Unit | Remark |
|---------------------|--------------------------|-------|---------|
| Screen Size | 2.9 | Inch | |
| Display Resolution | 296(V)×128(H) | Pixel | DPI:112 |
| Active Area | 29.06×66.90 | mm | |
| Pixel Pitch | 0.226×0.227 | mm | |
| Pixel Configuration | Rectangle | | |
| Outline Dimension | 36.7(H)×79.0 (V) ×1.2(D) | mm | |
| Weight | 6.64±0.5 | g | |

| Temperature Range(°C) | | 0-9 | 10-19 | 20-29 | 30-40 | Units |
|-----------------------|--------|------|-------|-------|-------|-------|
| White State | TYP L* | 64 | 63 | 63 | 63 | |
| | MIN L* | 62 | 62 | 62 | 62 | |
| | a* | ≤0 | ≤0 | ≤0 | ≤0 | |
| | b* | ≤2.5 | ≤2.5 | ≤2.5 | ≤2.5 | |
| Black State | TYP L* | 9 | 9 | 9 | 9 | |
| | MAX L* | 11 | 11 | 11 | 11 | |
| | a* | ≤9 | ≤9 | ≤8 | ≤10 | |
| Red State | MIN L* | 23 | 23 | 24 | 23 | |
| | TYP a* | 36 | 38 | 40 | 40 | |
| | MIN a* | 34 | 34 | 38 | 38 | |
| | MAX b* | 34 | 34 | 34 | 34 | |
| Yellow State | MIN L* | 50 | 50 | 54 | 54 | |
| | TYP b* | 55 | 63 | 66 | 66 | |
| | MIN b* | 53 | 56 | 60 | 60 | |
| | MAX a* | 18 | 18 | 18 | 18 | |
| Ghosting | | ≤2 | ≤2 | ≤2 | ≤2 | |

Notes: 3-1. Luminance meter: Eye-One Pro Spectrophotometer.



4. Mechanical Drawing of EPD Module

| | | | |
|---------------|------------|------|--------------|
| Confirmation: | DATE | REV. | MODIFICATION |
| | 2023-02-10 | A | FIRST ISSUE |

FRONT VIEW

SIDE VIEW

BACK VIEW

NOTE

- 1 DISPLAY MODULE 2.9" ARRAY FOR EPD
- 2 DRIVER IC: JD79661
- 3 RESOLUTION: 296gateX128source
- 4 PIXEL SIZE: 0.226mmX0.227mm

| | | | | | |
|---------------------|--------|------------------|-------|------------|------------|
| TOLERANCES UNMARKED | TITLE: | PROJECT: | REV.: | DATE: | CUST. P/N: |
| ANGLES±5° | EPD | OKRA0290RYF661F6 | A | 23.02.10 | |
| .X=±0.4mm | DWN: | CHK: | UNIT: | 3RD ANGLE: | PAGE: |
| .XX=±0.20mm | Z FU | CC ZHENG | mm | | 1/1 |
| .XXX=±0.20mm | | SY ZHAO | | | |

**5. Input/output Pin Assignment**

| No. | Name | I/O | Description | Remark |
|-----|-------|-----|--|-----------|
| 1 | NC | | Do not connect with other NC pins | Keep Open |
| 2 | GDR | O | N-Channel MOSFET Gate Drive Control | |
| 3 | RESE | I | Current Sense Input for the Control Loop | |
| 4 | NC | | Do not connect with other NC pins | Keep Open |
| 5 | VSH2 | C | Positive Source driving voltage(Red) | |
| 6 | TSCL | O | I2C Interface to digital temperature sensor Clock pin | Note 5-6 |
| 7 | TSDA | I/O | I2C Interface to digital temperature sensor Data pin | Note 5-6 |
| 8 | BS1 | I | Bus Interface selection pin | Note 5-5 |
| 9 | BUSY | O | Busy state output pin | Note 5-4 |
| 10 | RES# | I | Reset signal input. Active Low. | Note 5-3 |
| 11 | D/C# | I | Data /Command control pin | Note 5-2 |
| 12 | CS# | I | Chip select input pin | Note 5-1 |
| 13 | SCL | I | Serial Clock pin (SPI) | |
| 14 | SDA | I/O | Serial Data pin (SPI) | |
| 15 | VDDIO | P | Power Supply for interface logic pins It should be connected with VCI | |
| 16 | VCI | P | Power Supply for the chip | |
| 17 | VSS | P | Ground | |
| 18 | VDD | C | Core logic power pin VDD can be regulated internally from VCI. A capacitor should be connected between VDD and VSS | |
| 19 | VPP | P | FOR TEST | Keep Open |
| 20 | VSH1 | C | Positive Source driving voltage | |
| 21 | VGH | C | Power Supply pin for Positive Gate driving voltage and VSH1 | |
| 22 | VSL | C | Negative Source driving voltage | |
| 23 | VGL | C | Power Supply pin for Negative Gate driving voltage VCOM and VSL | |
| 24 | VCOM | C | VCOM driving voltage | |



I = Input Pin, O =Output Pin, I/O = Bi-directional Pin (Input/output), P = Power Pin, C = Capacitor Pin

Note 5-1: This pin (CS#) is the chip select input connecting to the MCU. The chip is enabled for MCU communication only when CS# is pulled LOW.

Note 5-2: This pin is (D/C#) Data/Command control pin connecting to the MCU in 4-wire SPI mode. When the pin is pulled HIGH, the data at SDA will be interpreted as data. When the pin is pulled LOW, the data at SDA will be interpreted as command.

Note 5-3: This pin (RES#) is reset signal input. The Reset is active low.

Note 5-4: This pin is Busy state output pin. When Busy is Low, the operation of chip should not be interrupted, command should not be sent. The chip would put Busy pin Low when -Outputting display waveform -Communicating with digital temperature sensor

Note 5-5: Bus interface selection pin

Note 5-6: This pin connect to the VSS if there is no external temperature sensor.

| BS1 State | MCU Interface |
|-----------|--|
| L | 4-lines serial peripheral interface(SPI) - 8 bits SPI |
| H | 3- lines serial peripheral interface(SPI) - 9 bits SPI |

6. Electrical Characteristics

6.1 Absolute Maximum Rating

| Parameter | Symbol | Rating | Unit |
|--------------------------|--------|------------------|------|
| Logic supply voltage | VCI | -0.3 to +6.0 | V |
| Logic Input voltage | VIN | -0.3 to VCI +0.3 | V |
| Operating Temp range | TOPR | 0 to +40 | °C. |
| Storage Temp range | TSTG | -25 to+70 | °C. |
| Optimal Storage Temp | TST Go | 23±2 | °C. |
| Optimal Storage Humidity | HST Go | 55±10 | %RH |

Note:

1. Maximum ratings are those values beyond which damages to the device may occur. Functional operation should be restricted to the limits in the Panel DC Characteristics tables.
2. The storage time is within 10 days for -25°C ~ 70°C.
The display screen should be kept white and face up.

6.2 Panel DC Characteristics

The following specifications apply for: VSS=0V, VCI=3.0V, TOPR =23°C.

| Parameter | Symbol | Condition | Applicable pin | Min. | Typ. | Max. | Unit |
|---------------------------|-----------------------|---|-----------------|-------------------------|--------|---------------------|------|
| Single ground | V _{SS} | - | | - | 0 | - | V |
| Logic supply voltage | V _{CI} | - | V _{CI} | 2.3 | 3.0 | 3.6 | V |
| Core logic voltage | V _{DD} | | V _{DD} | 2.3 | 3.0 | 3.6 | V |
| High level input voltage | V _{IH} | - | - | 0.7 V _{CI} | - | V _{CI} | V |
| Low level input voltage | V _{IL} | - | - | 0 | - | 0.3 V _{CI} | V |
| High level output voltage | V _{OH} | I _{OH} = 400Ma | - | V _{CI} -0.4 | - | - | V |
| Low level output voltage | V _{OL} | I _{OL} = -400Ma | - | - | - | GND +0.4 | V |
| Typical power | P _{TYP} | V _{CI} =3.0V | - | - | 13.5 | - | mW |
| Deep sleep mode | P _{STPY} | V _{CI} =3.0V | - | - | 0.0012 | - | mW |
| Typical operating current | I _{opr_VCI} | V _{CI} =3.0V | - | - | 4.5 | - | mA |
| Image update time | - | 23 °C | - | - | 20 | - | sec |
| Deep sleep mode current | I _{dslp_VCI} | DC/DC off No clock No input load Ram data not retain | - | - | 0.4 | 1 | uA |

Notes: 1. The typical power is measured with following transition from horizontal 4 scale pattern to vertical 4 scale pattern.

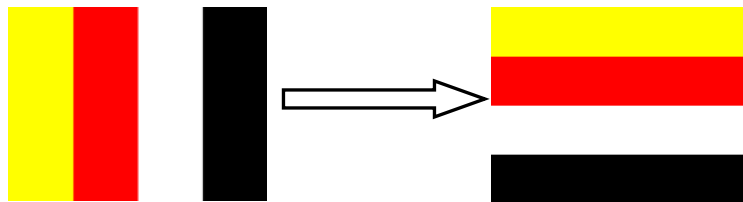

- 2. The deep sleep power is the consumed power when the panel controller is in deep sleep mode.**
- 3. The listed electrical/optical characteristics are only guaranteed under the controller & waveform provided by OKRA.**
- 4. Electrical measurement: Tektronix oscilloscope - MDO3024,
Tektronix current probe - TCP0030A.**



6.3 Panel AC Characteristics

6.3.1 MCU Interface Selection

The pin assignment at different interface mode is summarized in Table 6-3-1. Different MCU mode can be set by hardware selection on BS1 pins. The display panel only supports 4-wire SPI or 3-wire SPI interface mode.

| Pin Name | Data/Command Interface | | Control Signal | | |
|------------------|------------------------|-----|----------------|------|------|
| | SDA | SCL | CS# | D/C# | RES# |
| Bus interface | SDA | SCL | CS# | D/C# | RES# |
| BS1=L 4-wire SPI | SDA | SCL | CS# | D/C# | RES# |
| BS1=H 3-wire SPI | SDA | SCL | CS# | L | RES# |

Table 6-3-1: MCU interface assignment under different bus interface mode

6.3.2 MCU Serial Interface (4-wire SPI)

The serial interface consists of serial clock SCL, serial data SDA, D/C#, CS#. This interface supports Write mode and Read mode.

| Function | CS# | D/C# | SCL |
|---------------|-----|------|-----|
| Write command | L | L | ↑ |
| Write data | L | H | ↑ |

Table 6-3-2: Control pins of 4-wire Serial Peripheral interface

Note: ↑ stands for rising edge of signal

Figure 6-3-1: 4-wire SPI mode

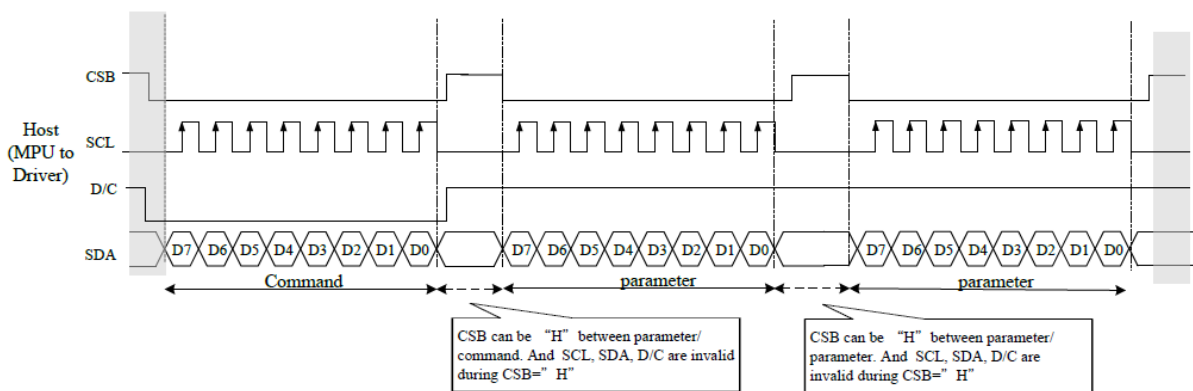



6.3.3 MCU Serial Interface (3-wire SPI)

| Function | CS# | D/C# | SCL |
|---------------|-----|------|-----|
| Write command | L | Tie | ↑ |
| Write data | L | Tie | ↑ |

Table 6-3-3: Control pins of 4-wire Serial Peripheral interface

Note: ↑ stands for rising edge of signal

Figure 6-3-2: 3-wire SPI mode

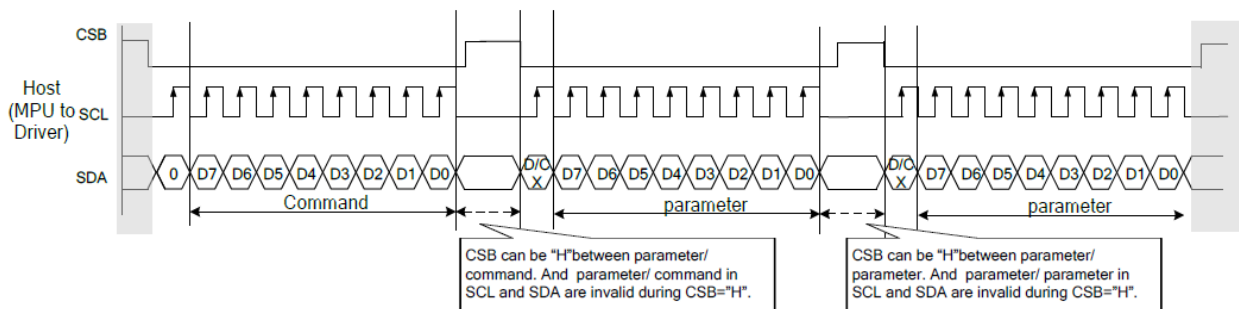

6.3.4 Interface Timing

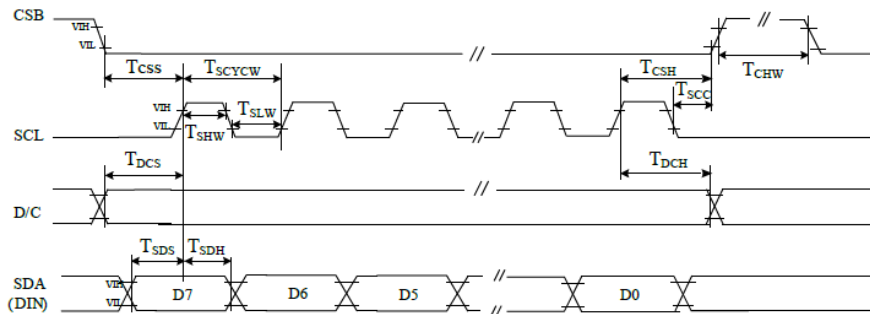

4 pin serial interface characteristics(write mode)

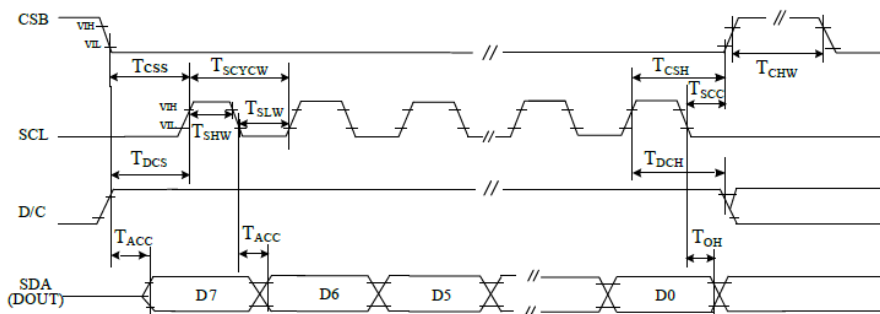

**Serial Interface Timing Characteristics**

| Parameter | Symbol | Min. | Typ. | Max. | Unit | Condition |
|-----------------------------|--------------------|------|------|------|------|-----------------------------|
| SERIAL COMMUNICATION | | | | | | |
| CSB | T _{CS} | 60 | | | ns | Chip select setup time |
| | T _{CSH} | 65 | | | ns | Chip select hold time |
| | T _{SCC} | 20 | | | ns | Chip select CSB setup time |
| | T _{CHW} | 40 | | | ns | Chip select setup time |
| SCL | T _{SCYCW} | 100 | | | ns | Serial clock cycle (Write) |
| | T _{SHW} | 35 | | | ns | SCL "H" pulse width (Write) |
| | T _{SLW} | 35 | | | ns | SCL "L" pulse width (Write) |
| | T _{SCYCR} | 150 | | | ns | Serial clock cycle (Read) |
| | T _{SHR} | 60 | | | ns | SCL "H" pulse width (Read) |
| | T _{SLR} | 60 | | | ns | SCL "L" pulse width (Read) |
| SDA (DIN) (DOUT) | T _{SDS} | 30 | | | ns | Data setup time |
| | T _{SDH} | 30 | | | ns | Data hold time |
| | T _{ACC} | | | 10 | ns | Access time |
| | T _{OH} | 15 | | | ns | Output disable time |
| D/C | T _{DCS} | 20 | | | ns | DC setup time |
| | T _{DCH} | 20 | | | ns | DC hold time |



7.Command Table

R/W: 0:Write Cycle 1:Read Cycle D/CX:0:Command/1:Data D7~D0:-:Don't Care

1)R00H (PSR): Panel setting Register

| R00H | Bit | | | | | | | | | | |
|---------------------------|-----|------|--------|--------|----------|------|---------|------|-------|---------|------|
| Inst/Para | R/W | D/CX | D7 | D6 | D5 | D4 | D3 | D2 | D1 | D0 | Code |
| PSR | W | 0 | 0 | 0 | 0 | 0 | 0 | 0 | 0 | 0 | 00H |
| 1 st Parameter | W | 1 | RES[1] | RES[0] | PST_MODE | - | UD | SHL | SHD_N | RST_N | 0Fh |
| 2 nd Parameter | W | 1 | LUT_EN | - | FOPT | VCMZ | TS_AUTO | TIEG | NORG | VC_LUTZ | 09h |

NOTE: "-" Don't care, can be set to VDD or GND level

| Description | -The command defines as : | | |
|-------------|---------------------------|----------|---|
| | 1 st parameter | | |
| | Bit | Name | Description |
| | 0 | RST_N | RST_N function 1: no effect. (default) 0: Booster OFF, Register data are set to their default values, and Source/Boder/Vcom: floating |
| | 1 | SHD_N | SHD_N function 0 : Booster OFF, register data are kept, and Source/Boder/Vcom are kept 0V or floating. 1 : Booster on. (default) |
| | 2 | SHL | SHL function 0: Shift left; First data=S _n →S _{n-1} →...→S ₂ →Last data=S ₁ . 1: Shift right: First data=S ₁ →S ₂ →...→S _{n-1} →Last data=S _n . (default) |
| | 3 | UD | UD function 0: Scan down; First line=G _n →G _{n-1} →...→G ₂ →Last line=G ₁ . 1: Scan up; First line=G ₁ →G ₂ →...→G _{n-1} →Last line=G _n . (default) |
| | 5 | PST_MODE | Power switch operation mode 0:Power switching time in the period of frame scanning. (default) 1:Power switching time in the external period before frame scanning. |
| | 7-6 | RES[1,0] | Resolution setting 00: Display resolution is 176x296 (default) 01: Display resolution is 128x296 10: Display resolution is 128x250 11: Display resolution is 112x204 |



| 2 nd parameter | | |
|---|---------|---|
| Bit | Name | Description |
| 0 | VC_LUTZ | VCOM status function 0 : No effect 1 : After refreshing display,the output of VCOM is set to floating automatically (default) |
| 1 | NORG | VCOM status function 0 : No effect (default) 1 : After refreshing display, VCOM is tied to GND before power off |
| 2 | TIEG | VGN power off status function 0 : No effect (default) 1 : Power off, VGN will be tied to GND |
| 3 | TS_AUTO | Temperature sensing will be activated automatically one time 0 : Before enabling booster, Temperature Sensor will be activated automatically one time. 1 : When RST_N low to high, Temperature Sensor will be activated automatically one time. (default) |
| 4 | VCMZ | VCOM status function 0 : No effect (default) 1 : VCOM is always floating |
| 5 | FOPT | FOPT function 0: Scan 1 frame after waveform finished(default) 1: No scan after waveform finished and switch the source channel output to Hiz. |
| 7 | LUT_EN | LUT selection setting 0 : Using LUT from MTP(default) 1 : Using LUT from register |
| <p>Priority of VCOM setting: VCMZ > NORG > FOPT > VC_LUTZ</p> <p>FOPT setting is part of refreshing display. FOPT: Power off floating.</p> <p>Notes:</p> <ol style="list-style-type: none"> 1. Non-select gate line keep at VGN for DSP/DRF and AMV 2. Dummy source line follow LUTC for DSP/DRF 3. When SHD_N become low, DCDC will turn off. Register and SRAM data will keep until VDD turn off. SD output and VCOM will base on previous condition. It may have two condition: 0V or floating. 4. When RST_N become low, driver will reset. All register will reset to default value. All of the driver's functions will disable. Source/Gate/Border/VCOM will be released to floating | | |
| Restriction | | |



2) R01H (PWR): Power setting Register

| R01H | Bit | | | | | | | | | | | |
|---------------------------|-----|------|----|--------------|----|----|--------|--------|----------|----------|------|-----|
| Inst/Para | R/W | D/CX | D7 | D6 | D5 | D4 | D3 | D2 | D1 | D0 | Code | |
| PWR | W | 0 | 0 | 0 | 0 | 0 | 0 | 0 | 0 | 1 | 01h | |
| 1 st Parameter | W | 1 | - | - | - | - | V_MODE | VSC_EN | VDS_EN | VDG_EN | 07h | |
| 2 nd Parameter | W | 1 | - | - | - | - | - | - | VGPN [1] | VGPN [0] | 00h | |
| 3 rd Parameter | W | 1 | - | VSPL_0 [6:0] | | | | | | | | 00h |
| 4 th Parameter | W | 1 | - | VSP_1 [6:0] | | | | | | | | 00h |
| 5 th Parameter | W | 1 | - | VSN_1 [6:0] | | | | | | | | 00h |
| 6 th Parameter | W | 1 | - | VSPL_1 [6:0] | | | | | | | | 00h |

NOTE: "-" Don't care, can be set to VDD or GND level

| | | | |
|-------------|----------------------------|--------|---|
| Description | -The command defines as : | | |
| | 1 st Parameter: | | |
| | Bit | Name | Description |
| | 0 | VDG_EN | Gate power selection. 0 : External gate power from VGP/VGN pins. 1 : Internal DCDC function for generate VGP/VGN. (default) |
| | 1 | VDS_EN | Source power selection. 0 : External source power from VSP/VSN pins. 1 : Internal regulator function for generate VSP/VSN (default) |
| | 2 | VSC_EN | Source LV power selection. 0 : External source power from VSPL pins. 1 : Internal regulator function for generate VSPL (default) |
| | 3 | V_MODE | Source Power switching mode. 0: Mode0(default) 1: Mode1 |
| | 2nd Parameter: | | |
| | Bit | Name | Description |
| | 1-0 | VGPN | VGPN Voltage Level. 00: VGP=20 v, VGN=-20v (default) 01: VGP=17 v, VGN=-17v 10: VGP=15 v, VGN=-15v 11: VGP=10 v, VGN=-10v |



3rd & 4th & 6th Parameter: Internal VSP_1/VSP_L_0/ VSPL_1 power selection

| Bit | Name | Description | | | | | |
|--------------------------------------|------|-------------|------------|-----------|------------|-----------|------------|
| Internal VSP & VSPL power selection. | | | | | | | |
| | | bit[6:0] | Voltage(V) | bit [6:0] | Voltage(V) | bit [6:0] | Voltage(V) |
| | | 0000000 | 00h 3 | 0101001 | 29h 7.1 | 1010010 | 52h 11.2 |
| | | 0000001 | 01h 3.1 | 0101010 | 2Ah 7.2 | 1010011 | 53h 11.3 |
| | | 0000010 | 02h 3.2 | 0101011 | 2Bh 7.3 | 1010100 | 54h 11.4 |
| | | 0000011 | 03h 3.3 | 0101100 | 2Ch 7.4 | 1010101 | 55h 11.5 |
| | | 0000100 | 04h 3.4 | 0101101 | 2Dh 7.5 | 1010110 | 56h 11.6 |
| | | 0000101 | 05h 3.5 | 0101110 | 2Eh 7.6 | 1010111 | 57h 11.7 |
| | | 0000110 | 06h 3.6 | 0101111 | 2Fh 7.7 | 1011000 | 58h 11.8 |
| | | 0000111 | 07h 3.7 | 0110000 | 30h 7.8 | 1011001 | 59h 11.9 |
| | | 0001000 | 08h 3.8 | 0110001 | 31h 7.9 | 1011010 | 5Ah 12 |
| | | 0001001 | 09h 3.9 | 0110010 | 32h 8 | 1011011 | 5Bh 12.1 |
| | | 0001010 | 0Ah 4 | 0110011 | 33h 8.1 | 1011100 | 5Ch 12.2 |
| | | 0001011 | 0Bh 4.1 | 0110100 | 34h 8.2 | 1011101 | 5Dh 12.3 |
| | | 0001100 | 0Ch 4.2 | 0110101 | 35h 8.3 | 1011110 | 5Eh 12.4 |
| | | 0001101 | 0Dh 4.3 | 0110110 | 36h 8.4 | 1011111 | 5Fh 12.5 |
| | | 0001110 | 0Eh 4.4 | 0110111 | 37h 8.5 | 1100000 | 60h 12.6 |
| | | 0001111 | 0Fh 4.5 | 0111000 | 38h 8.6 | 1100001 | 61h 12.7 |
| | | 0010000 | 10h 4.6 | 0111001 | 39h 8.7 | 1100010 | 62h 12.8 |
| | | 0010001 | 11h 4.7 | 0111010 | 3Ah 8.8 | 1100011 | 63h 12.9 |
| | | 0010010 | 12h 4.8 | 0111011 | 3Bh 8.9 | 1100100 | 64h 13 |
| | | 0010011 | 13h 4.9 | 0111100 | 3Ch 9 | 1100101 | 65h 13.1 |
| | | 0010100 | 14h 5 | 0111101 | 3Dh 9.1 | 1100110 | 66h 13.2 |
| | | 0010101 | 15h 5.1 | 0111110 | 3Eh 9.2 | 1100111 | 67h 13.3 |
| | | 0010110 | 16h 5.2 | 0111111 | 3Fh 9.3 | 1101000 | 68h 13.4 |
| | | 0010111 | 17h 5.3 | 1000000 | 40h 9.4 | 1101001 | 69h 13.5 |
| | | 0011000 | 18h 5.4 | 1000001 | 41h 9.5 | 1101010 | 6Ah 13.6 |
| | | 0011001 | 19h 5.5 | 1000010 | 42h 9.6 | 1101011 | 6Bh 13.7 |
| | | 0011010 | 1Ah 5.6 | 1000011 | 43h 9.7 | 1101100 | 6Ch 13.8 |
| | | 0011011 | 1Bh 5.7 | 1000100 | 44h 9.8 | 1101101 | 6Dh 13.9 |
| | | 0011100 | 1Ch 5.8 | 1000101 | 45h 9.9 | 1101110 | 6Eh 14 |
| | | 0011101 | 1Dh 5.9 | 1000110 | 46h 10 | 1101111 | 6Fh 14.1 |
| | | 0011110 | 1Eh 6 | 1000111 | 47h 10.1 | 1110000 | 70h 14.2 |
| | | 0011111 | 1Fh 6.1 | 1001000 | 48h 10.2 | 1110001 | 71h 14.3 |
| | | 0100000 | 20h 6.2 | 1001001 | 49h 10.3 | 1110010 | 72h 14.4 |
| | | 0100001 | 21h 6.3 | 1001010 | 4Ah 10.4 | 1110011 | 73h 14.5 |
| | | 0100010 | 22h 6.4 | 1001011 | 4Bh 10.5 | 1110100 | 74h 14.6 |
| | | 0100011 | 23h 6.5 | 1001100 | 4Ch 10.6 | 1110101 | 75h 14.7 |
| | | 0100100 | 24h 6.6 | 1001101 | 4Dh 10.7 | 1110110 | 76h 14.8 |
| | | 0100101 | 25h 6.7 | 1001110 | 4Eh 10.8 | 1110111 | 77h 14.9 |
| | | 0100110 | 26h 6.8 | 1001111 | 4Fh 10.9 | 1111000 | 78h 15 |
| | | 0100111 | 27h 6.9 | 1010000 | 50h 11 | other | 15 |
| | | 0101000 | 28h 7 | 1010001 | 51h 11.1 | | |

6-0
VSP_1
&
VSPL_0
&
VSPL_1



5th Parameter: Internal VSN_1 power selection

| Bit | Name | Description | | | | | | | |
|-------------------------------|-------|-------------|------------|----------|------------|----------|------------|----------|------------|
| Internal VSN power selection. | | | | | | | | | |
| | | bit[6:0] | Voltage(V) | bit[6:0] | Voltage(V) | bit[6:0] | Voltage(V) | bit[6:0] | Voltage(V) |
| | | 0000000 | 00h -3 | 0101001 | 29h -7.1 | 1010010 | 52h -11.2 | | |
| | | 0000001 | 01h -3.1 | 0101010 | 2Ah -7.2 | 1010011 | 53h -11.3 | | |
| | | 0000010 | 02h -3.2 | 0101011 | 2Bh -7.3 | 1010100 | 54h -11.4 | | |
| | | 0000011 | 03h -3.3 | 0101100 | 2Ch -7.4 | 1010101 | 55h -11.5 | | |
| | | 0000100 | 04h -3.4 | 0101101 | 2Dh -7.5 | 1010110 | 56h -11.6 | | |
| | | 0000101 | 05h -3.5 | 0101110 | 2Eh -7.6 | 1010111 | 57h -11.7 | | |
| | | 0000110 | 06h -3.6 | 0101111 | 2Fh -7.7 | 1011000 | 58h -11.8 | | |
| | | 0000111 | 07h -3.7 | 0110000 | 30h -7.8 | 1011001 | 59h -11.9 | | |
| | | 0001000 | 08h -3.8 | 0110001 | 31h -7.9 | 1011010 | 5Ah -12 | | |
| | | 0001001 | 09h -3.9 | 0110010 | 32h -8 | 1011011 | 5Bh -12.1 | | |
| | | 0001010 | 0Ah -4 | 0110011 | 33h -8.1 | 1011100 | 5Ch -12.2 | | |
| | | 0001011 | 0Bh -4.1 | 0110100 | 34h -8.2 | 1011101 | 5Dh -12.3 | | |
| | | 0001100 | 0Ch -4.2 | 0110101 | 35h -8.3 | 1011110 | 5Eh -12.4 | | |
| | | 0001101 | 0Dh -4.3 | 0110110 | 36h -8.4 | 1011111 | 5Fh -12.5 | | |
| | | 0001110 | 0Eh -4.4 | 0110111 | 37h -8.5 | 1100000 | 60h -12.6 | | |
| | | 0001111 | 0Fh -4.5 | 0111000 | 38h -8.6 | 1100001 | 61h -12.7 | | |
| | | 0010000 | 10h -4.6 | 0111001 | 39h -8.7 | 1100010 | 62h -12.8 | | |
| | | 0010001 | 11h -4.7 | 0111010 | 3Ah -8.8 | 1100011 | 63h -12.9 | | |
| | | 0010010 | 12h -4.8 | 0111011 | 3Bh -8.9 | 1100100 | 64h -13 | | |
| | | 0010011 | 13h -4.9 | 0111100 | 3Ch -9 | 1100101 | 65h -13.1 | | |
| 6-0 | VSN_1 | 0010100 | 14h -5 | 0111101 | 3Dh -9.1 | 1100110 | 66h -13.2 | | |
| | | 0010101 | 15h -5.1 | 0111110 | 3Eh -9.2 | 1100111 | 67h -13.3 | | |
| | | 0010110 | 16h -5.2 | 0111111 | 3Fh -9.3 | 1101000 | 68h -13.4 | | |
| | | 0010111 | 17h -5.3 | 1000000 | 40h -9.4 | 1101001 | 69h -13.5 | | |
| | | 0011000 | 18h -5.4 | 1000001 | 41h -9.5 | 1101010 | 6Ah -13.6 | | |
| | | 0011001 | 19h -5.5 | 1000010 | 42h -9.6 | 1101011 | 6Bh -13.7 | | |
| | | 0011010 | 1Ah -5.6 | 1000011 | 43h -9.7 | 1101100 | 6Ch -13.8 | | |
| | | 0011011 | 1Bh -5.7 | 1000100 | 44h -9.8 | 1101101 | 6Dh -13.9 | | |
| | | 0011100 | 1Ch -5.8 | 1000101 | 45h -9.9 | 1101110 | 6Eh -14 | | |
| | | 0011101 | 1Dh -5.9 | 1000110 | 46h -10 | 1101111 | 6Fh -14.1 | | |
| | | 0011110 | 1Eh -6 | 1000111 | 47h -10.1 | 1110000 | 70h -14.2 | | |
| | | 0011111 | 1Fh -6.1 | 1001000 | 48h -10.2 | 1110001 | 71h -14.3 | | |
| | | 0100000 | 20h -6.2 | 1001001 | 49h -10.3 | 1110010 | 72h -14.4 | | |
| | | 0100001 | 21h -6.3 | 1001010 | 4Ah -10.4 | 1110011 | 73h -14.5 | | |
| | | 0100010 | 22h -6.4 | 1001011 | 4Bh -10.5 | 1110100 | 74h -14.6 | | |
| | | 0100011 | 23h -6.5 | 1001100 | 4Ch -10.6 | 1110101 | 75h -14.7 | | |
| | | 0100100 | 24h -6.6 | 1001101 | 4Dh -10.7 | 1110110 | 76h -14.8 | | |
| | | 0100101 | 25h -6.7 | 1001110 | 4Eh -10.8 | 1110111 | 77h -14.9 | | |
| | | 0100110 | 26h -6.8 | 1001111 | 4Fh -10.9 | 1111000 | 78h -15 | | |
| | | 0100111 | 27h -6.9 | 1010000 | 50h -11 | other | -15 | | |
| | | 0101000 | 28h -7 | 1010001 | 51h -7.1 | | | | |



Notes:

- 1. VSP_0/VSN_0 voltage output is ±15 V fixed value.
- 2. When switching Mode0 or Mode1, the voltage output is:
 Mode0: VSP_0(+15) / VSN_0 (-15) / VSPL_0 (+3~+15)
 Mode1: VSP_1(+3 ~ +15) / VSN_1(-3 ~ -15) / VSPL_1(+3 ~ +15)

| | Mode0 | Mode1 |
|------|----------------|----------------|
| VSP | VSP_0(+15) | VSP_1(+3~+15) |
| VSN | VSN_0(-15) | VSN_1(-3~-15) |
| VSPL | VSPL_0(+3~+15) | VSPL_1(+3~+15) |

- 3. If gate voltage is set to +/-15v, +/-10v, IC will auto correct source voltage as follows
 I. VGP- VSP_0 / VSPL_0 / VSP_1 / VSPL_1 >= 2v
 II. VGN- VSN_0 / VSN_1 >= -2v
 For example:

| | symbol | Voltage setting | Real Voltage |
|---------|--------|-----------------|--------------|
| Voltage | VGP | 10v | +10v |
| | VGN | 10v | -10v |
| | VSP_0 | +15v | +8v |
| | VSN_0 | -15v | -8v |
| | VSP_1 | +5v | +5v |
| | VSN_1 | -5v | -5v |
| | VSPL | +15v | +8v |
| | VCOMH | +15v+(-2v) | +8v+(-2v) |
| | VCOML | -15v+(-2v) | -8v+(-2v) |
| | VCOMDC | -2v | -2v |

- 4. Voltage setting limit: VSP_0 ≥ VSPL_0 , VSP_1 ≥ VSPL_1

Restriction



3)R02H (POF): Power OFF Command

| R02H | Bit | | | | | | | | | | |
|---------------------------|-----|------|----|----|----|----|----|----|----|------|------|
| Inst/Para | R/W | D/CX | D7 | D6 | D5 | D4 | D3 | D2 | D1 | D0 | Code |
| POF | W | 0 | 0 | 0 | 0 | 0 | 0 | 0 | 1 | 0 | 02H |
| 1 st Parameter | W | 0 | - | - | - | - | - | - | - | EDSE | 00 |

NOTE: "-" Don't care, can be set to VDD or GND level

| Description | <p>-The command defines as :</p> <ul style="list-style-type: none"> ● After power off command, driver will power off base on power off sequence. ● After power off command, BUSY_N signal will drop from high to low. When finish the power off sequence, BUSY_N signal will rise from low to high. ● Power off command will turn off charge pump, T-con, source driver, gate driver, VCOM, temperature sensor, but register and SRAM data will keep until VDD off. ● SD output and VCOM will base on previous condition. It may have two conditions: 0v or floating. <p>1st parameter</p> <table border="1"> <thead> <tr> <th>Bit</th> <th>Name</th> <th>Description</th> </tr> </thead> <tbody> <tr> <td>0</td> <td>EDSE</td> <td>EPD Discharge Trigger 0 : Disable EPD discharge (default) 1 : Enable EPD discharge</td> </tr> </tbody> </table> | Bit | Name | Description | 0 | EDSE | EPD Discharge Trigger 0 : Disable EPD discharge (default) 1 : Enable EPD discharge |
|-------------|--|--|------|-------------|---|------|--|
| Bit | Name | Description | | | | | |
| 0 | EDSE | EPD Discharge Trigger 0 : Disable EPD discharge (default) 1 : Enable EPD discharge | | | | | |
| Restriction | This command only active when BUSY_N = "1". | | | | | | |



4)R03H (PFS): Power off Sequence Setting Register

| R03H | Bit | | | | | | | | | | |
|---------------------------|-----|------|--------------|----|------------------|----|--------------|----|-----------------|----|------|
| Inst/Para | R/W | D/CX | D7 | D6 | D5 | D4 | D3 | D2 | D1 | D0 | Code |
| PFS | W | 0 | 0 | 0 | 0 | 0 | 0 | 0 | 1 | 1 | 03H |
| 1 st Parameter | W | 1 | - | | T_VDPG_OFF [1:0] | | - | | T_VDS_OFF [1:0] | | 00h |
| 2 nd Parameter | W | 1 | VGP_LEN[3:0] | | | | VGP_EXT[3:0] | | | | 54h |
| 3 rd Parameter | W | 1 | XON_DLY[3:0] | | | | XON_LEN[3:0] | | | | 44h |

NOTE: "-" Don't care, can be set to VDD or GND level

| Description | -The command defines as : | | |
|-------------|----------------------------|-------------|--|
| | 1 st Parameter: | | |
| | Bit | Name | Description |
| | 1-0 | T_VDS_OFF | Power off sequence of VSP /VSN 00: 20 ms (default) 01: 40 ms 10: 60 ms 11: 80 ms |
| | 5-4 | T_VDPG_OFF | Power off sequence of VGP and VGN 00: 20 ms (default) 01: 40 ms 10: 60 ms 11: 80 ms |
| | 2 nd Parameter | | |
| | Bit | Name | Description |
| | 1-0 | VGP_EXT | VGP extension time 0000: 0 ms 0001: 500 ms 0010: 1000 ms 0011: 1500 ms 0100: 2000 ms (default) 0101: 2500 ms 0110: 3000 ms 0111: 3500 ms 1000: 4000 ms 1001: 4500 ms 1010: 5000 ms 1011: 5500 ms 1100: 6000 ms 1101: 6500 ms |
| | 7-4 | VGP_LEN | When power off, the length of time VGP stay 10V 0000: 0 ms 0001: 500 ms 0010: 1000 ms 0011: 1500 ms 0100: 2000 ms 0101: 2500 ms (default) 0110: 3000 ms 0111: 3500 ms 1000: 4000 ms 1001: 4500 ms 1010: 5000 ms 1011: 5500 ms |



| | | 1100: 6000 ms 1101: 6500 ms |
|---------------------|---------|--|
| 3-Parameter: | | |
| Bit | Name | Description |
| 3-0 | XON_LEN | XON enable time 0000: 0 ms 0001: 500 ms 0010: 1000 ms 0011: 1500 ms 0100: 2000 ms (default) 0101: 2500 ms 0110: 3000 ms 0111: 3500 ms 1000: 4000 ms 1001: 4500 ms 1010: 5000 ms 1011: 5500 ms 1100: 6000 ms |
| 7-4 | XON_DLY | XON delay time 0000: 0 ms 0001: 500 ms 0010: 1000 ms 0011: 1500 ms 0100: 2000 ms (default) 0101: 2500 ms 0110: 3000 ms 0111: 3500 ms 1000: 4000 ms 1001: 4500 ms 1010: 5000 ms 1011: 5500 ms 1100: 6000 ms |
| Restriction | | |



5)(R04H) (PON):Power ON Command

| R04H | Bit | | | | | | | | | | |
|-----------|-----|------|----|----|----|----|----|----|----|----|------|
| Inst/Para | R/W | D/CX | D7 | D6 | D5 | D4 | D3 | D2 | D1 | D0 | Code |
| PON | W | 0 | 0 | 0 | 0 | 0 | 0 | 1 | 0 | 0 | 04H |

NOTE: "-" Don't care, can be set to VDD or GND level

| | |
|-------------|---|
| Description | -The command defines as : <ul style="list-style-type: none"> ● After power on command, driver will power on base on power on sequence. ● After power on command, BUSY_N signal will drop from high to low. When finishing the power on sequence(base on PWR command), BUSY_N signal will rise from low to high. |
| Restriction | This command only active when BUSY_N = "1". |



6) R06H (BTST): Booster Soft Start Command

| R06H | Bit | | | | | | | | | | |
|---------------------------|-----|------|----|----|---------------|----|---------------|----|---------------|----|------|
| Inst/Para | R/W | D/CX | D7 | D6 | D5 | D4 | D3 | D2 | D1 | D0 | Code |
| BTST | W | 0 | 0 | 0 | 0 | 0 | 0 | 1 | 1 | 0 | 06H |
| 1 st Parameter | W | 1 | - | - | - | - | PHB_SFT [1:0] | | PHA_SFT [1:0] | | 00h |
| 2 nd Parameter | W | 1 | - | - | PHA_ON [5:0] | | | | | | 02h |
| 3 rd Parameter | W | 1 | - | - | PHA_OFF [5:0] | | | | | | 07h |
| 4 th Parameter | W | 1 | - | - | PHB_ON [5:0] | | | | | | 02h |
| 5 th Parameter | W | 1 | - | - | PHB_OFF [5:0] | | | | | | 07h |
| 6 th Parameter | W | 1 | - | - | PHC_ON [5:0] | | | | | | 02h |
| 7 th Parameter | W | 1 | - | - | PHC_OFF [5:0] | | | | | | 07h |

| | | | | | | | | |
|-------------|---|--|---|-------------|----------|-------------|----------|-------------|
| Description | -The command define as follows: 1 st Parameter: | | | | | | | |
| | Bit | Name | Description | | | | | |
| | 1-0 | PHA_SFT | Soft start period of phase A: 00: 10mS (default) 01: 20mS 10: 30mS 11: 40mS | | | | | |
| | 3-2 | PHB_SFT | Soft start period of phase B: 00: 10mS (default) 01: 20mS 10: 30mS 11: 40mS | | | | | |
| | | | Bit[5:0] | Description | Bit[5:0] | Description | Bit[5:0] | Description |
| | | Driving strength of PHA_ON & PHB_ON & PHC_ON | 000000 | strength1 | 010110 | strength23 | 101100 | strength45 |
| | | | 000001 | strength2 | 010111 | strength24 | 101101 | strength46 |
| | | | 000010 | strength3 | 011000 | strength25 | 101110 | strength47 |
| | | | 000011 | strength4 | 011001 | strength26 | 101111 | strength48 |
| | | | 000100 | strength5 | 011010 | strength27 | 110000 | strength49 |
| | | | 000101 | strength6 | 011011 | strength28 | 110001 | strength50 |
| | | | 000110 | strength7 | 011100 | strength29 | 110010 | strength51 |
| | | | 000111 | strength8 | 011101 | strength30 | 110011 | strength52 |
| | | | 001000 | strength9 | 011110 | strength31 | 110100 | strength53 |
| | | | 001001 | strength10 | 011111 | strength32 | 110101 | strength54 |
| | | | 001010 | strength11 | 100000 | strength33 | 110110 | strength55 |
| | | | 001011 | strength12 | 100001 | strength34 | 110111 | strength56 |
| | | | 001100 | strength13 | 100010 | strength35 | 111000 | strength57 |
| | | | 001101 | strength14 | 100011 | strength36 | 111001 | strength58 |
| | | | 001110 | strength15 | 100100 | strength37 | 111010 | strength59 |
| | | | 001111 | strength16 | 100101 | strength38 | 111011 | strength60 |
| | | | 010000 | strength17 | 100110 | strength39 | 111100 | strength61 |
| | | | 010001 | strength18 | 100111 | strength40 | 111101 | strength62 |
| | | | 010010 | strength19 | 101000 | strength41 | 111110 | strength63 |
| | | | 010011 | strength20 | 101001 | strength42 | 111111 | strength64 |
| | | | 010100 | strength21 | 101010 | strength43 | | |
| | | | 010101 | strength22 | 101011 | strength44 | | |



| Description | Bit[5:0] | | Bit[5:0] | | Bit[5:0] | |
|---|----------|-------------|----------|-------------|----------|-------------|
| | Bit[5:0] | Description | Bit[5:0] | Description | Bit[5:0] | Description |
| Minimum OFF time setting of PHA_OFF & PHB_OFF & PHC_OFF | 000000 | Period1 | 010110 | Period23 | 101100 | Period45 |
| | 000001 | Period2 | 010111 | Period24 | 101101 | Period46 |
| | 000010 | Period3 | 011000 | Period25 | 101110 | Period47 |
| | 000011 | Period4 | 011001 | Period26 | 101111 | Period48 |
| | 000100 | Period5 | 011010 | Period27 | 110000 | Period49 |
| | 000101 | Period6 | 011011 | Period28 | 110001 | Period50 |
| | 000110 | Period7 | 011100 | Period29 | 110010 | Period51 |
| | 000111 | Period8 | 011101 | Period30 | 110011 | Period52 |
| | 001000 | Period9 | 011110 | Period31 | 110100 | Period53 |
| | 001001 | Period10 | 011111 | Period32 | 110101 | Period54 |
| | 001010 | Period11 | 100000 | Period33 | 110110 | Period55 |
| | 001011 | Period12 | 100001 | Period34 | 110111 | Period56 |
| | 001100 | Period13 | 100010 | Period35 | 111000 | Period57 |
| | 001101 | Period14 | 100011 | Period36 | 111001 | Period58 |
| | 001110 | Period15 | 100100 | Period37 | 111010 | Period59 |
| | 001111 | Period16 | 100101 | Period38 | 111011 | Period60 |
| | 010000 | Period17 | 100110 | Period39 | 111100 | Period61 |
| | 010001 | Period18 | 100111 | Period40 | 111101 | Period62 |
| | 010010 | Period19 | 101000 | Period41 | 111110 | Period63 |
| | 010011 | Period20 | 101001 | Period42 | 111111 | Period64 |
| | 010100 | Period21 | 101010 | Period43 | | |
| | 010101 | Period22 | 101011 | Period44 | | |
| Restriction | | | | | | |



7) R07H (DSLPL): Deep Sleep Command

| R07H | Bit | | | | | | | | | | |
|---------------------------|-----|------|----|----|----|----|----|----|----|----|------|
| Inst/Para | R/W | D/CX | D7 | D6 | D5 | D4 | D3 | D2 | D1 | D0 | Code |
| DSLPL | W | 0 | 0 | 0 | 0 | 0 | 0 | 1 | 1 | 1 | 07H |
| 1 st Parameter | W | 1 | 1 | 0 | 1 | 0 | 0 | 1 | 0 | 1 | A5h |

NOTE: "-" Don't care, can be set to VDD or GND level

| | |
|-------------|---|
| Description | <p>The command define as follows: After this command is transmitted, the chip would enter the deep-sleep mode to save power. The deep sleep mode would return to standby by hardware reset. The only one parameter is a check code, the command would be excited if check code = 0xA5.</p> |
| Restriction | This command only active when BUSY_N = "1". |

8) R10H (DTM): Data Start transmission Register

| R10H | Bit | | | | | | | | | | |
|---------------------------|-----|------|------------|----|------------|----|------------|----|----------|----|------|
| Inst/Para | R/W | D/CX | D7 | D6 | D5 | D4 | D3 | D2 | D1 | D0 | Code |
| DTM | W | 0 | 0 | 0 | 0 | 1 | 0 | 0 | 0 | 0 | 10H |
| 2 bit mode | W | 1 | | | | | | | | | |
| 1 st Parameter | W | 1 | Pixel1 | | Pixel2 | | Pixel3 | | Pixel4 | | 00h |
| ⋮ | W | 1 | ⋮ | ⋮ | ⋮ | ⋮ | ⋮ | ⋮ | ⋮ | ⋮ | 00h |
| M th Parameter | W | 1 | Pixel(n-3) | | Pixel(n-2) | | Pixel(n-1) | | Pixel(n) | | 00h |

NOTE: "-" Don't care, can be set to VDD or GND level

| Description | <p>The command define as follows: The register is indicates that user start to transmit data, then write to SRAM. While data transmission complete, user must send command 12H. Then chip will start to send data/VCOM for panel.</p> <p>Pixel [1~n][1:0]: 2-bit/pixel</p> <table border="1"> <thead> <tr> <th>Image Data</th> <th colspan="2">DDX=1 (default)</th> <th colspan="2">DDX=0</th> </tr> <tr> <th>Pixel[1:0]</th> <th>Gray level select</th> <th>IP output LUT select</th> <th>Gray level select</th> <th>IP output LUT select</th> </tr> </thead> <tbody> <tr> <td>00b</td> <td>Gray0</td> <td>ogray00</td> <td>Gray3</td> <td>ogray03</td> </tr> <tr> <td>01b</td> <td>Gray1</td> <td>ogray01</td> <td>Gray2</td> <td>ogray02</td> </tr> <tr> <td>10b</td> <td>Gray2</td> <td>ogray02</td> <td>Gray1</td> <td>ogray01</td> </tr> <tr> <td>11b</td> <td>Gray3</td> <td>ogray03</td> <td>Gray0</td> <td>ogray00</td> </tr> </tbody> </table> <p>Data mapping example: When DDX=1, Pixel[1:0]=01 -> Gray level select=Gray1, follow LUT data output from IP output port"ogray01". When DDX=0, Pixel[1:0]=11 -> Gray level select=Gray0, follow LUT data output from IP output port"ogray00"</p> | Image Data | DDX=1 (default) | | DDX=0 | | Pixel[1:0] | Gray level select | IP output LUT select | Gray level select | IP output LUT select | 00b | Gray0 | ogray00 | Gray3 | ogray03 | 01b | Gray1 | ogray01 | Gray2 | ogray02 | 10b | Gray2 | ogray02 | Gray1 | ogray01 | 11b | Gray3 | ogray03 | Gray0 | ogray00 |
|-------------|---|----------------------|-------------------|----------------------|-------|--|------------|-------------------|----------------------|-------------------|----------------------|-----|-------|---------|-------|---------|-----|-------|---------|-------|---------|-----|-------|---------|-------|---------|-----|-------|---------|-------|---------|
| Image Data | DDX=1 (default) | | DDX=0 | | | | | | | | | | | | | | | | | | | | | | | | | | | | |
| Pixel[1:0] | Gray level select | IP output LUT select | Gray level select | IP output LUT select | | | | | | | | | | | | | | | | | | | | | | | | | | | |
| 00b | Gray0 | ogray00 | Gray3 | ogray03 | | | | | | | | | | | | | | | | | | | | | | | | | | | |
| 01b | Gray1 | ogray01 | Gray2 | ogray02 | | | | | | | | | | | | | | | | | | | | | | | | | | | |
| 10b | Gray2 | ogray02 | Gray1 | ogray01 | | | | | | | | | | | | | | | | | | | | | | | | | | | |
| 11b | Gray3 | ogray03 | Gray0 | ogray00 | | | | | | | | | | | | | | | | | | | | | | | | | | | |
| Restriction | | | | | | | | | | | | | | | | | | | | | | | | | | | | | | | |



9)R11H (DSP): Data Stop Command

| R11H | Bit | | | | | | | | | | |
|---------------------------|-----|------|-----------|----|----|----|----|----|----|----|------|
| Inst/Para | R/W | D/CX | D7 | D6 | D5 | D4 | D3 | D2 | D1 | D0 | Code |
| DSP | W | 0 | 0 | 0 | 0 | 1 | 0 | 0 | 0 | 1 | 11H |
| 1 st Parameter | R | 1 | Data_flag | - | - | - | - | - | - | - | - |

NOTE: "-" Don't care, can be set to VDD or GND level

| Description | <p>-The command defines as :</p> <ul style="list-style-type: none"> While finished the data transmitting, user must send this command to driver and read Data_flag information. <p>1st Parameter:</p> <table border="1"> <thead> <tr> <th>Bit</th> <th>Name</th> <th>Description</th> </tr> </thead> <tbody> <tr> <td>7</td> <td>Data_flag</td> <td>0: Driver didn't receive all the data. 1: Driver has already received all of the one frame data.</td> </tr> </tbody> </table> <p>After "Data Start" (10h) or "Data Stop" (11h) commands and when data_flag=1, BUSY_N signal will become "0" and the refreshing of panel starts.</p> | Bit | Name | Description | 7 | Data_flag | 0: Driver didn't receive all the data. 1: Driver has already received all of the one frame data. |
|-------------|---|---|------|-------------|---|-----------|---|
| Bit | Name | Description | | | | | |
| 7 | Data_flag | 0: Driver didn't receive all the data. 1: Driver has already received all of the one frame data. | | | | | |
| Restriction | This command only actives when BUSY_N = "1". | | | | | | |

10)R12H (DRF): Display Refresh Command

| R12H | Bit | | | | | | | | | | |
|---------------------------|-----|------|----|----|----|----|----|----|----|------------|------|
| Inst/Para | R/W | D/CX | D7 | D6 | D5 | D4 | D3 | D2 | D1 | D0 | Code |
| DRF | W | 0 | 0 | 0 | 0 | 1 | 0 | 0 | 1 | 0 | 12H |
| 1 st Parameter | W | 1 | - | - | - | - | - | - | - | AC/DC VCOM | 00h |

NOTE: "-" Don't care, can be set to VDD or GND level

| | |
|-------------|--|
| Description | <p>-The command defines as :</p> <p>While users send this command, driver will refresh display (data/VCOM) base on SRAM data and LUT.</p> <p>AC/DC VCOM:</p> <p>0: AC VCOM, VCOM will follow LUTC when updating image. (default) 1: DC VCOM, VCOM will always be VCOMDC when updating image</p> <p>After display refresh command, BUSY_N signal will become "0"</p> |
| Restriction | This command only actives when BUSY_N = "1" |



11) R17H (AUTO): Auto Sequence

| R17H | Bit | | | | | | | | | | |
|---------------------------|-----|------|---------|---------|---------|---------|---------|---------|---------|---------|------|
| Inst/Para | R/W | D/CX | D7 | D6 | D5 | D4 | D3 | D2 | D1 | D0 | Code |
| Auto Sequence | W | 0 | 0 | 0 | 0 | 1 | 0 | 1 | 1 | 1 | 17H |
| 1 st Parameter | W | 1 | Code[7] | Code[6] | Code[5] | Code[4] | Code[3] | Code[2] | Code[1] | Code[0] | A5h |

| | |
|-------------|---|
| Description | <p>The command can enable the internal sequence to execute several commands continuously. The successive execution can minimize idle time to avoid unnecessary power consumption and reduce the complexity of host's control procedure. The sequence contains several operations, including PON, DRF, POF, DSLP.</p> <p>AUTO (0x17) + Code(0xA5) = (PON→DRF→POF) AUTO (0x17) + Code(0xA7) = (PON→DRF→POF→DSLP)</p> |
| Restriction | This command only actives when BUSY_N = "1". |



12) R30H (PLL): PLL Control Register

| R30H | Bit | | | | | | | | | | |
|---------------------------|-----|------|----|----|----|----|------|-------|-------|-------|------|
| Inst/Para | R/W | D/CX | D7 | D6 | D5 | D4 | D3 | D2 | D1 | D0 | Code |
| PLL | W | 0 | 0 | 0 | 1 | 1 | 0 | 0 | 0 | 0 | 30H |
| 1 st Parameter | W | 1 | - | - | - | - | Dyna | FR[2] | FR[1] | FR[0] | 02h |

NOTE: "-" Don't care, can be set to VDD or GND level

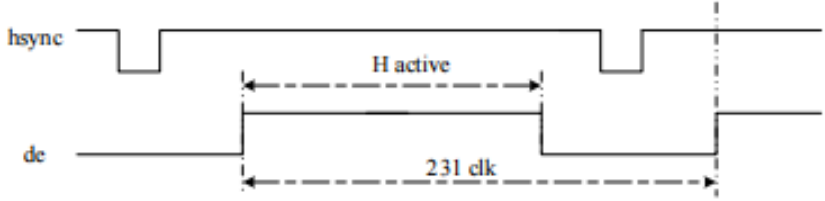
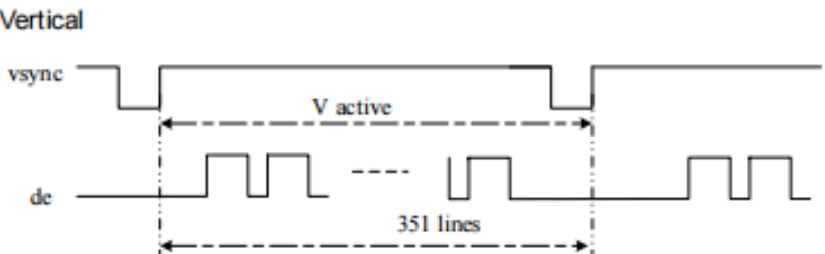
| Description | <p>-The command defines as:</p> <p>The command controls the PLL clock frequency. The PLL structure must support the following frame rates:</p> <table border="1" data-bbox="711 546 1107 676"> <thead> <tr> <th>bit3</th> <th>Dynamic frame rate</th> </tr> </thead> <tbody> <tr> <td>0</td> <td>Disable (default)</td> </tr> <tr> <td>1</td> <td>Enable</td> </tr> </tbody> </table> <table border="1" data-bbox="711 709 1107 1081"> <thead> <tr> <th>FR[2:0]</th> <th>Frame rate</th> </tr> </thead> <tbody> <tr> <td>000</td> <td>12.5 Hz</td> </tr> <tr> <td>001</td> <td>25 Hz</td> </tr> <tr> <td>010</td> <td>50 Hz (default)</td> </tr> <tr> <td>011</td> <td>65 Hz</td> </tr> <tr> <td>100</td> <td>75 Hz</td> </tr> <tr> <td>101</td> <td>85 Hz</td> </tr> <tr> <td>110</td> <td>100 Hz</td> </tr> <tr> <td>111</td> <td>120 Hz</td> </tr> </tbody> </table> | bit3 | Dynamic frame rate | 0 | Disable (default) | 1 | Enable | FR[2:0] | Frame rate | 000 | 12.5 Hz | 001 | 25 Hz | 010 | 50 Hz (default) | 011 | 65 Hz | 100 | 75 Hz | 101 | 85 Hz | 110 | 100 Hz | 111 | 120 Hz |
|-------------|--|------|--------------------|---|-------------------|---|--------|---------|------------|-----|---------|-----|-------|-----|-----------------|-----|-------|-----|-------|-----|-------|-----|--------|-----|--------|
| bit3 | Dynamic frame rate | | | | | | | | | | | | | | | | | | | | | | | | |
| 0 | Disable (default) | | | | | | | | | | | | | | | | | | | | | | | | |
| 1 | Enable | | | | | | | | | | | | | | | | | | | | | | | | |
| FR[2:0] | Frame rate | | | | | | | | | | | | | | | | | | | | | | | | |
| 000 | 12.5 Hz | | | | | | | | | | | | | | | | | | | | | | | | |
| 001 | 25 Hz | | | | | | | | | | | | | | | | | | | | | | | | |
| 010 | 50 Hz (default) | | | | | | | | | | | | | | | | | | | | | | | | |
| 011 | 65 Hz | | | | | | | | | | | | | | | | | | | | | | | | |
| 100 | 75 Hz | | | | | | | | | | | | | | | | | | | | | | | | |
| 101 | 85 Hz | | | | | | | | | | | | | | | | | | | | | | | | |
| 110 | 100 Hz | | | | | | | | | | | | | | | | | | | | | | | | |
| 111 | 120 Hz | | | | | | | | | | | | | | | | | | | | | | | | |
| remark | <p>-Horizontal</p>  <p>-Vertical</p>  | | | | | | | | | | | | | | | | | | | | | | | | |
| Restriction | | | | | | | | | | | | | | | | | | | | | | | | | |



13)R40H (TSC): Temperature Sensor Command

| R40H | Bit | | | | | | | | | | |
|---------------------------|-----|------|-----------|----------|----------|----------|----------|----------|----------|----------|------|
| Inst/Para | R/W | D/CX | D7 | D6 | D5 | D4 | D3 | D2 | D1 | D0 | Code |
| TSC | W | 0 | 0 | 1 | 0 | 0 | 0 | 0 | 0 | 0 | 40H |
| 1 st Parameter | R | 1 | D10/TS[7] | D9/TS[6] | D8/TS[5] | D7/TS[4] | D6/TS[3] | D5/TS[2] | D4/TS[1] | D3/TS[0] | - |
| 2 nd Parameter | R | 1 | D2/TS[9] | D1/TS[8] | D0 | - | - | - | - | - | - |

NOTE: "-" Don't care, can be set to VDD or GND level

| Description | <p>-The command define as follows: This command indicates the temperature value. If R41H(TSE) bit7 set to 0, this command reads internal temperature sensor value. If R41H(TSE) bit7 set to 1, this command reads external (LM75) temperature sensor value</p> | | | | | | | | | | | | | | | | | | | | | | | | | | | | | | | | | | | | | | | | | | | | | | | | | | | | | | | | | | | | | | | | | | | | | | | | | | | | | | | | | | | | | | | | | | | | | | | | | | | | | | | | | | | | | | | | | | | | | | | | | | | | | | | | | | | | | | | | | | | | | | | | | | | | | | | | | | | | | | | | | | | | | |
|----------------|---|----------------|--------|----------------|--------|----------------|--------|----------|-----|----------|---|----------|----|----------|-----|----------|---|----------|----|----------|-----|----------|---|----------|----|----------|-----|----------|---|----------|----|----------|-----|----------|---|----------|----|----------|-----|----------|---|----------|----|----------|-----|----------|---|----------|----|----------|-----|----------|---|----------|----|----------|-----|----------|---|----------|----|----------|-----|----------|---|----------|----|----------|-----|----------|----|----------|----|----------|-----|----------|----|----------|----|----------|-----|----------|----|----------|----|----------|-----|----------|----|----------|----|----------|-----|----------|----|----------|----|----------|-----|----------|----|----------|----|----------|----|----------|----|----------|----|----------|----|----------|----|----------|----|----------|----|----------|----|----------|----|----------|----|----------|----|----------|----|----------|----|----------|----|----------|----|----------|----|----------|----|----------|----|----------|----|----------|----|----------|----|----------|----|----------|----|----------|----|----------|----|----------|----|----------|----|---------|--------|----|----|----|-------|----|------|----|
| | <table border="1"> <thead> <tr> <th>TS[7:0]D[10:3]</th> <th>T (°C)</th> <th>TS[7:0]D[10:3]</th> <th>T (°C)</th> <th>TS[7:0]D[10:3]</th> <th>T (°C)</th> </tr> </thead> <tbody> <tr><td>11100111</td><td>-25</td><td>00000000</td><td>0</td><td>00011001</td><td>25</td></tr> <tr><td>11101000</td><td>-24</td><td>00000001</td><td>1</td><td>00011010</td><td>26</td></tr> <tr><td>11101001</td><td>-23</td><td>00000010</td><td>2</td><td>00011011</td><td>27</td></tr> <tr><td>11101010</td><td>-22</td><td>00000011</td><td>3</td><td>00011100</td><td>28</td></tr> <tr><td>11101011</td><td>-21</td><td>00000100</td><td>4</td><td>00011101</td><td>29</td></tr> <tr><td>11101100</td><td>-20</td><td>00000101</td><td>5</td><td>00011110</td><td>30</td></tr> <tr><td>11101101</td><td>-19</td><td>00000110</td><td>6</td><td>00011111</td><td>31</td></tr> <tr><td>11101110</td><td>-18</td><td>00000111</td><td>7</td><td>00100000</td><td>32</td></tr> <tr><td>11101111</td><td>-17</td><td>00001000</td><td>8</td><td>00100001</td><td>33</td></tr> <tr><td>11110000</td><td>-16</td><td>00001001</td><td>9</td><td>00100010</td><td>34</td></tr> <tr><td>11110001</td><td>-15</td><td>00001010</td><td>10</td><td>00100011</td><td>35</td></tr> <tr><td>11110010</td><td>-14</td><td>00001011</td><td>11</td><td>00100100</td><td>36</td></tr> <tr><td>11110011</td><td>-13</td><td>00001100</td><td>12</td><td>00100101</td><td>37</td></tr> <tr><td>11110100</td><td>-12</td><td>00001101</td><td>13</td><td>00100110</td><td>38</td></tr> <tr><td>11110101</td><td>-11</td><td>00001110</td><td>14</td><td>00100111</td><td>39</td></tr> <tr><td>11110110</td><td>-10</td><td>00001111</td><td>15</td><td>00101000</td><td>40</td></tr> <tr><td>11110111</td><td>-9</td><td>00010000</td><td>16</td><td>00101001</td><td>41</td></tr> <tr><td>11111000</td><td>-8</td><td>00010001</td><td>17</td><td>00101010</td><td>42</td></tr> <tr><td>11111001</td><td>-7</td><td>00010010</td><td>18</td><td>00101011</td><td>43</td></tr> <tr><td>11111010</td><td>-6</td><td>00010011</td><td>19</td><td>00101100</td><td>44</td></tr> <tr><td>11111011</td><td>-5</td><td>00010100</td><td>20</td><td>00101101</td><td>45</td></tr> <tr><td>11111100</td><td>-4</td><td>00010101</td><td>21</td><td>00101110</td><td>46</td></tr> <tr><td>11111101</td><td>-3</td><td>00010110</td><td>22</td><td>00101111</td><td>47</td></tr> <tr><td>11111110</td><td>-2</td><td>00010111</td><td>23</td><td>00110000</td><td>48</td></tr> <tr><td>11111111</td><td>-1</td><td>00011000</td><td>24</td><td>00110001</td><td>49</td></tr> </tbody> </table> <table border="1"> <thead> <tr> <th>TS[9:8]</th> <th>T (°C)</th> </tr> </thead> <tbody> <tr><td>00</td><td>+0</td></tr> <tr><td>01</td><td>+0.25</td></tr> <tr><td>10</td><td>+0.5</td></tr> <tr><td>11</td><td>+0.75</td></tr> </tbody> </table> | TS[7:0]D[10:3] | T (°C) | TS[7:0]D[10:3] | T (°C) | TS[7:0]D[10:3] | T (°C) | 11100111 | -25 | 00000000 | 0 | 00011001 | 25 | 11101000 | -24 | 00000001 | 1 | 00011010 | 26 | 11101001 | -23 | 00000010 | 2 | 00011011 | 27 | 11101010 | -22 | 00000011 | 3 | 00011100 | 28 | 11101011 | -21 | 00000100 | 4 | 00011101 | 29 | 11101100 | -20 | 00000101 | 5 | 00011110 | 30 | 11101101 | -19 | 00000110 | 6 | 00011111 | 31 | 11101110 | -18 | 00000111 | 7 | 00100000 | 32 | 11101111 | -17 | 00001000 | 8 | 00100001 | 33 | 11110000 | -16 | 00001001 | 9 | 00100010 | 34 | 11110001 | -15 | 00001010 | 10 | 00100011 | 35 | 11110010 | -14 | 00001011 | 11 | 00100100 | 36 | 11110011 | -13 | 00001100 | 12 | 00100101 | 37 | 11110100 | -12 | 00001101 | 13 | 00100110 | 38 | 11110101 | -11 | 00001110 | 14 | 00100111 | 39 | 11110110 | -10 | 00001111 | 15 | 00101000 | 40 | 11110111 | -9 | 00010000 | 16 | 00101001 | 41 | 11111000 | -8 | 00010001 | 17 | 00101010 | 42 | 11111001 | -7 | 00010010 | 18 | 00101011 | 43 | 11111010 | -6 | 00010011 | 19 | 00101100 | 44 | 11111011 | -5 | 00010100 | 20 | 00101101 | 45 | 11111100 | -4 | 00010101 | 21 | 00101110 | 46 | 11111101 | -3 | 00010110 | 22 | 00101111 | 47 | 11111110 | -2 | 00010111 | 23 | 00110000 | 48 | 11111111 | -1 | 00011000 | 24 | 00110001 | 49 | TS[9:8] | T (°C) | 00 | +0 | 01 | +0.25 | 10 | +0.5 | 11 |
| TS[7:0]D[10:3] | T (°C) | TS[7:0]D[10:3] | T (°C) | TS[7:0]D[10:3] | T (°C) | | | | | | | | | | | | | | | | | | | | | | | | | | | | | | | | | | | | | | | | | | | | | | | | | | | | | | | | | | | | | | | | | | | | | | | | | | | | | | | | | | | | | | | | | | | | | | | | | | | | | | | | | | | | | | | | | | | | | | | | | | | | | | | | | | | | | | | | | | | | | | | | | | | | | | | | | | | | | | | | | |
| 11100111 | -25 | 00000000 | 0 | 00011001 | 25 | | | | | | | | | | | | | | | | | | | | | | | | | | | | | | | | | | | | | | | | | | | | | | | | | | | | | | | | | | | | | | | | | | | | | | | | | | | | | | | | | | | | | | | | | | | | | | | | | | | | | | | | | | | | | | | | | | | | | | | | | | | | | | | | | | | | | | | | | | | | | | | | | | | | | | | | | | | | | | | | | |
| 11101000 | -24 | 00000001 | 1 | 00011010 | 26 | | | | | | | | | | | | | | | | | | | | | | | | | | | | | | | | | | | | | | | | | | | | | | | | | | | | | | | | | | | | | | | | | | | | | | | | | | | | | | | | | | | | | | | | | | | | | | | | | | | | | | | | | | | | | | | | | | | | | | | | | | | | | | | | | | | | | | | | | | | | | | | | | | | | | | | | | | | | | | | | | |
| 11101001 | -23 | 00000010 | 2 | 00011011 | 27 | | | | | | | | | | | | | | | | | | | | | | | | | | | | | | | | | | | | | | | | | | | | | | | | | | | | | | | | | | | | | | | | | | | | | | | | | | | | | | | | | | | | | | | | | | | | | | | | | | | | | | | | | | | | | | | | | | | | | | | | | | | | | | | | | | | | | | | | | | | | | | | | | | | | | | | | | | | | | | | | | |
| 11101010 | -22 | 00000011 | 3 | 00011100 | 28 | | | | | | | | | | | | | | | | | | | | | | | | | | | | | | | | | | | | | | | | | | | | | | | | | | | | | | | | | | | | | | | | | | | | | | | | | | | | | | | | | | | | | | | | | | | | | | | | | | | | | | | | | | | | | | | | | | | | | | | | | | | | | | | | | | | | | | | | | | | | | | | | | | | | | | | | | | | | | | | | | |
| 11101011 | -21 | 00000100 | 4 | 00011101 | 29 | | | | | | | | | | | | | | | | | | | | | | | | | | | | | | | | | | | | | | | | | | | | | | | | | | | | | | | | | | | | | | | | | | | | | | | | | | | | | | | | | | | | | | | | | | | | | | | | | | | | | | | | | | | | | | | | | | | | | | | | | | | | | | | | | | | | | | | | | | | | | | | | | | | | | | | | | | | | | | | | | |
| 11101100 | -20 | 00000101 | 5 | 00011110 | 30 | | | | | | | | | | | | | | | | | | | | | | | | | | | | | | | | | | | | | | | | | | | | | | | | | | | | | | | | | | | | | | | | | | | | | | | | | | | | | | | | | | | | | | | | | | | | | | | | | | | | | | | | | | | | | | | | | | | | | | | | | | | | | | | | | | | | | | | | | | | | | | | | | | | | | | | | | | | | | | | | | |
| 11101101 | -19 | 00000110 | 6 | 00011111 | 31 | | | | | | | | | | | | | | | | | | | | | | | | | | | | | | | | | | | | | | | | | | | | | | | | | | | | | | | | | | | | | | | | | | | | | | | | | | | | | | | | | | | | | | | | | | | | | | | | | | | | | | | | | | | | | | | | | | | | | | | | | | | | | | | | | | | | | | | | | | | | | | | | | | | | | | | | | | | | | | | | | |
| 11101110 | -18 | 00000111 | 7 | 00100000 | 32 | | | | | | | | | | | | | | | | | | | | | | | | | | | | | | | | | | | | | | | | | | | | | | | | | | | | | | | | | | | | | | | | | | | | | | | | | | | | | | | | | | | | | | | | | | | | | | | | | | | | | | | | | | | | | | | | | | | | | | | | | | | | | | | | | | | | | | | | | | | | | | | | | | | | | | | | | | | | | | | | | |
| 11101111 | -17 | 00001000 | 8 | 00100001 | 33 | | | | | | | | | | | | | | | | | | | | | | | | | | | | | | | | | | | | | | | | | | | | | | | | | | | | | | | | | | | | | | | | | | | | | | | | | | | | | | | | | | | | | | | | | | | | | | | | | | | | | | | | | | | | | | | | | | | | | | | | | | | | | | | | | | | | | | | | | | | | | | | | | | | | | | | | | | | | | | | | | |
| 11110000 | -16 | 00001001 | 9 | 00100010 | 34 | | | | | | | | | | | | | | | | | | | | | | | | | | | | | | | | | | | | | | | | | | | | | | | | | | | | | | | | | | | | | | | | | | | | | | | | | | | | | | | | | | | | | | | | | | | | | | | | | | | | | | | | | | | | | | | | | | | | | | | | | | | | | | | | | | | | | | | | | | | | | | | | | | | | | | | | | | | | | | | | | |
| 11110001 | -15 | 00001010 | 10 | 00100011 | 35 | | | | | | | | | | | | | | | | | | | | | | | | | | | | | | | | | | | | | | | | | | | | | | | | | | | | | | | | | | | | | | | | | | | | | | | | | | | | | | | | | | | | | | | | | | | | | | | | | | | | | | | | | | | | | | | | | | | | | | | | | | | | | | | | | | | | | | | | | | | | | | | | | | | | | | | | | | | | | | | | | |
| 11110010 | -14 | 00001011 | 11 | 00100100 | 36 | | | | | | | | | | | | | | | | | | | | | | | | | | | | | | | | | | | | | | | | | | | | | | | | | | | | | | | | | | | | | | | | | | | | | | | | | | | | | | | | | | | | | | | | | | | | | | | | | | | | | | | | | | | | | | | | | | | | | | | | | | | | | | | | | | | | | | | | | | | | | | | | | | | | | | | | | | | | | | | | | |
| 11110011 | -13 | 00001100 | 12 | 00100101 | 37 | | | | | | | | | | | | | | | | | | | | | | | | | | | | | | | | | | | | | | | | | | | | | | | | | | | | | | | | | | | | | | | | | | | | | | | | | | | | | | | | | | | | | | | | | | | | | | | | | | | | | | | | | | | | | | | | | | | | | | | | | | | | | | | | | | | | | | | | | | | | | | | | | | | | | | | | | | | | | | | | | |
| 11110100 | -12 | 00001101 | 13 | 00100110 | 38 | | | | | | | | | | | | | | | | | | | | | | | | | | | | | | | | | | | | | | | | | | | | | | | | | | | | | | | | | | | | | | | | | | | | | | | | | | | | | | | | | | | | | | | | | | | | | | | | | | | | | | | | | | | | | | | | | | | | | | | | | | | | | | | | | | | | | | | | | | | | | | | | | | | | | | | | | | | | | | | | | |
| 11110101 | -11 | 00001110 | 14 | 00100111 | 39 | | | | | | | | | | | | | | | | | | | | | | | | | | | | | | | | | | | | | | | | | | | | | | | | | | | | | | | | | | | | | | | | | | | | | | | | | | | | | | | | | | | | | | | | | | | | | | | | | | | | | | | | | | | | | | | | | | | | | | | | | | | | | | | | | | | | | | | | | | | | | | | | | | | | | | | | | | | | | | | | | |
| 11110110 | -10 | 00001111 | 15 | 00101000 | 40 | | | | | | | | | | | | | | | | | | | | | | | | | | | | | | | | | | | | | | | | | | | | | | | | | | | | | | | | | | | | | | | | | | | | | | | | | | | | | | | | | | | | | | | | | | | | | | | | | | | | | | | | | | | | | | | | | | | | | | | | | | | | | | | | | | | | | | | | | | | | | | | | | | | | | | | | | | | | | | | | | |
| 11110111 | -9 | 00010000 | 16 | 00101001 | 41 | | | | | | | | | | | | | | | | | | | | | | | | | | | | | | | | | | | | | | | | | | | | | | | | | | | | | | | | | | | | | | | | | | | | | | | | | | | | | | | | | | | | | | | | | | | | | | | | | | | | | | | | | | | | | | | | | | | | | | | | | | | | | | | | | | | | | | | | | | | | | | | | | | | | | | | | | | | | | | | | | |
| 11111000 | -8 | 00010001 | 17 | 00101010 | 42 | | | | | | | | | | | | | | | | | | | | | | | | | | | | | | | | | | | | | | | | | | | | | | | | | | | | | | | | | | | | | | | | | | | | | | | | | | | | | | | | | | | | | | | | | | | | | | | | | | | | | | | | | | | | | | | | | | | | | | | | | | | | | | | | | | | | | | | | | | | | | | | | | | | | | | | | | | | | | | | | | |
| 11111001 | -7 | 00010010 | 18 | 00101011 | 43 | | | | | | | | | | | | | | | | | | | | | | | | | | | | | | | | | | | | | | | | | | | | | | | | | | | | | | | | | | | | | | | | | | | | | | | | | | | | | | | | | | | | | | | | | | | | | | | | | | | | | | | | | | | | | | | | | | | | | | | | | | | | | | | | | | | | | | | | | | | | | | | | | | | | | | | | | | | | | | | | | |
| 11111010 | -6 | 00010011 | 19 | 00101100 | 44 | | | | | | | | | | | | | | | | | | | | | | | | | | | | | | | | | | | | | | | | | | | | | | | | | | | | | | | | | | | | | | | | | | | | | | | | | | | | | | | | | | | | | | | | | | | | | | | | | | | | | | | | | | | | | | | | | | | | | | | | | | | | | | | | | | | | | | | | | | | | | | | | | | | | | | | | | | | | | | | | | |
| 11111011 | -5 | 00010100 | 20 | 00101101 | 45 | | | | | | | | | | | | | | | | | | | | | | | | | | | | | | | | | | | | | | | | | | | | | | | | | | | | | | | | | | | | | | | | | | | | | | | | | | | | | | | | | | | | | | | | | | | | | | | | | | | | | | | | | | | | | | | | | | | | | | | | | | | | | | | | | | | | | | | | | | | | | | | | | | | | | | | | | | | | | | | | | |
| 11111100 | -4 | 00010101 | 21 | 00101110 | 46 | | | | | | | | | | | | | | | | | | | | | | | | | | | | | | | | | | | | | | | | | | | | | | | | | | | | | | | | | | | | | | | | | | | | | | | | | | | | | | | | | | | | | | | | | | | | | | | | | | | | | | | | | | | | | | | | | | | | | | | | | | | | | | | | | | | | | | | | | | | | | | | | | | | | | | | | | | | | | | | | | |
| 11111101 | -3 | 00010110 | 22 | 00101111 | 47 | | | | | | | | | | | | | | | | | | | | | | | | | | | | | | | | | | | | | | | | | | | | | | | | | | | | | | | | | | | | | | | | | | | | | | | | | | | | | | | | | | | | | | | | | | | | | | | | | | | | | | | | | | | | | | | | | | | | | | | | | | | | | | | | | | | | | | | | | | | | | | | | | | | | | | | | | | | | | | | | | |
| 11111110 | -2 | 00010111 | 23 | 00110000 | 48 | | | | | | | | | | | | | | | | | | | | | | | | | | | | | | | | | | | | | | | | | | | | | | | | | | | | | | | | | | | | | | | | | | | | | | | | | | | | | | | | | | | | | | | | | | | | | | | | | | | | | | | | | | | | | | | | | | | | | | | | | | | | | | | | | | | | | | | | | | | | | | | | | | | | | | | | | | | | | | | | | |
| 11111111 | -1 | 00011000 | 24 | 00110001 | 49 | | | | | | | | | | | | | | | | | | | | | | | | | | | | | | | | | | | | | | | | | | | | | | | | | | | | | | | | | | | | | | | | | | | | | | | | | | | | | | | | | | | | | | | | | | | | | | | | | | | | | | | | | | | | | | | | | | | | | | | | | | | | | | | | | | | | | | | | | | | | | | | | | | | | | | | | | | | | | | | | | |
| TS[9:8] | T (°C) | | | | | | | | | | | | | | | | | | | | | | | | | | | | | | | | | | | | | | | | | | | | | | | | | | | | | | | | | | | | | | | | | | | | | | | | | | | | | | | | | | | | | | | | | | | | | | | | | | | | | | | | | | | | | | | | | | | | | | | | | | | | | | | | | | | | | | | | | | | | | | | | | | | | | | | | | | | | | | | | | | | | | |
| 00 | +0 | | | | | | | | | | | | | | | | | | | | | | | | | | | | | | | | | | | | | | | | | | | | | | | | | | | | | | | | | | | | | | | | | | | | | | | | | | | | | | | | | | | | | | | | | | | | | | | | | | | | | | | | | | | | | | | | | | | | | | | | | | | | | | | | | | | | | | | | | | | | | | | | | | | | | | | | | | | | | | | | | | | | | |
| 01 | +0.25 | | | | | | | | | | | | | | | | | | | | | | | | | | | | | | | | | | | | | | | | | | | | | | | | | | | | | | | | | | | | | | | | | | | | | | | | | | | | | | | | | | | | | | | | | | | | | | | | | | | | | | | | | | | | | | | | | | | | | | | | | | | | | | | | | | | | | | | | | | | | | | | | | | | | | | | | | | | | | | | | | | | | | |
| 10 | +0.5 | | | | | | | | | | | | | | | | | | | | | | | | | | | | | | | | | | | | | | | | | | | | | | | | | | | | | | | | | | | | | | | | | | | | | | | | | | | | | | | | | | | | | | | | | | | | | | | | | | | | | | | | | | | | | | | | | | | | | | | | | | | | | | | | | | | | | | | | | | | | | | | | | | | | | | | | | | | | | | | | | | | | | |
| 11 | +0.75 | | | | | | | | | | | | | | | | | | | | | | | | | | | | | | | | | | | | | | | | | | | | | | | | | | | | | | | | | | | | | | | | | | | | | | | | | | | | | | | | | | | | | | | | | | | | | | | | | | | | | | | | | | | | | | | | | | | | | | | | | | | | | | | | | | | | | | | | | | | | | | | | | | | | | | | | | | | | | | | | | | | | | |
| Restriction | This command only actives when BUSY_N = "1". | | | | | | | | | | | | | | | | | | | | | | | | | | | | | | | | | | | | | | | | | | | | | | | | | | | | | | | | | | | | | | | | | | | | | | | | | | | | | | | | | | | | | | | | | | | | | | | | | | | | | | | | | | | | | | | | | | | | | | | | | | | | | | | | | | | | | | | | | | | | | | | | | | | | | | | | | | | | | | | | | | | | | |



14)R41H (TSE): Temperature Sensor Calibration Register

| R41H | Bit | | | | | | | | | | |
|---------------------------|-----|------|-----|----|----|-------|-------|-------|-------|-------|------|
| Inst/Para | R/W | D/CX | D7 | D6 | D5 | D4 | D3 | D2 | D1 | D0 | Code |
| TSE | W | 0 | 0 | 1 | 0 | 0 | 0 | 0 | 0 | 1 | 41H |
| 1 st Parameter | W | 1 | TSE | - | - | TO[4] | TO[3] | TO[2] | TO[1] | TO[0] | 00h |

NOTE: "-" Don't care, can be set to VDD or GND level

| Description | -The command defines as: This command indicates the driver IC temperature sensor enable and calibration function. | | | | | | | | | | | | |
|-------------|--|--|------|-------------|-----|---------|--|---|-------|-----------------------------------|---|-----|---|
| | Reserve one temperature offset TO[3:0] for calibration | | | | | | | | | | | | |
| | 1. TO[3]: mean '+' or '-', while 0 is '+'; 1 is '-' | | | | | | | | | | | | |
| | 2. TO[2:0]: mean temperature offset value | | | | | | | | | | | | |
| | <table border="1"> <thead> <tr> <th>Bit</th> <th>Name</th> <th>Description</th> </tr> </thead> <tbody> <tr> <td>3-0</td> <td>TO[3:0]</td> <td>Temperature level: 0000: +0°C (default) 0001: +0.5°C 0010: +1°C 0011: +1.5°C 0100: +2°C 0101: +2.5°C 0110: +3°C 0111: +3.5°C 1000: -4°C 1001: -3.5°C 1010: -3°C 1011: -2.5°C 1100: -2°C 1101: -1.5°C 1110: -1°C 1111: -0.5°C</td> </tr> <tr> <td>4</td> <td>TO[4]</td> <td>0: +0.0°C (default) 1: +0.25°C</td> </tr> <tr> <td>7</td> <td>TSE</td> <td>Internal temperature sensor enable 0: Internal temperature sensor enable.(default) 1: Internal temperature sensor disable, using external temperature sensor.</td> </tr> </tbody> </table> | Bit | Name | Description | 3-0 | TO[3:0] | Temperature level: 0000: +0°C (default) 0001: +0.5°C 0010: +1°C 0011: +1.5°C 0100: +2°C 0101: +2.5°C 0110: +3°C 0111: +3.5°C 1000: -4°C 1001: -3.5°C 1010: -3°C 1011: -2.5°C 1100: -2°C 1101: -1.5°C 1110: -1°C 1111: -0.5°C | 4 | TO[4] | 0: +0.0°C (default) 1: +0.25°C | 7 | TSE | Internal temperature sensor enable 0: Internal temperature sensor enable.(default) 1: Internal temperature sensor disable, using external temperature sensor. |
| Bit | Name | Description | | | | | | | | | | | |
| 3-0 | TO[3:0] | Temperature level: 0000: +0°C (default) 0001: +0.5°C 0010: +1°C 0011: +1.5°C 0100: +2°C 0101: +2.5°C 0110: +3°C 0111: +3.5°C 1000: -4°C 1001: -3.5°C 1010: -3°C 1011: -2.5°C 1100: -2°C 1101: -1.5°C 1110: -1°C 1111: -0.5°C | | | | | | | | | | | |
| 4 | TO[4] | 0: +0.0°C (default) 1: +0.25°C | | | | | | | | | | | |
| 7 | TSE | Internal temperature sensor enable 0: Internal temperature sensor enable.(default) 1: Internal temperature sensor disable, using external temperature sensor. | | | | | | | | | | | |
| Restriction | This command only actives after R04H(PON) | | | | | | | | | | | | |



15)R42H (TSW): Temperature Sensor Write Register

| R42H | Bit | | | | | | | | | | |
|---------------------------|-----|------|----------|----------|----------|----------|----------|----------|----------|----------|------|
| Inst/Para | R/W | D/CX | D7 | D6 | D5 | D4 | D3 | D2 | D1 | D0 | Code |
| TSW | W | 0 | 0 | 1 | 0 | 0 | 0 | 0 | 1 | 0 | 42H |
| 1 st Parameter | W | 1 | WATTR[7] | WATTR[6] | WATTR[5] | WATTR[4] | WATTR[3] | WATTR[2] | WATTR[1] | WATTR[0] | 00h |
| 2 nd Parameter | W | 1 | WMSB[7] | WMSB[6] | WMSB[5] | WMSB[4] | WMSB[3] | WMSB[2] | WMSB[1] | WMSB[0] | 00h |
| 3 rd Parameter | W | 1 | WLSB[7] | WLSB[6] | WLSB[5] | WLSB[4] | WLSB[3] | WLSB[2] | WLSB[1] | WLSB[0] | 00h |

NOTE: "-" Don't care, can be set to VDD or GND level

| | | |
|---|---|------------|
| Description | -The command defines as: | |
| | This command writes the temperature. | |
| | 1 st Parameter: | |
| | Bit | Name |
| | 2-0 | WATTR[2:0] |
| | 5-3 | WATTR[5:3] |
| | 7-6 | WATTR[7:6] |
| | Description | |
| | Pointer setting | |
| | User-defined address bits (A2, A1, A0) | |
| I2C Write Byte Number 00: 1 byte (head byte only) 01: 2 bytes (head byte + pointer) 10: 3 bytes (head byte + pointer + 1st parameter) 11: 4 bytes (head byte + pointer + 1st parameter + 2nd parameter) | | |
| 2 nd Parameter: | | |
| Bit | Name | |
| 7-0 | WMSB[7:0] | |
| Description | | |
| MSByte of write-data to external temperature sensor | | |
| 3 rd Parameter: | | |
| Bit | Name | |
| 7-0 | WLSB[7:0] | |
| Description | | |
| LSByte of write-data to external temperature sensor | | |
| Restriction | This command only actives after R04H(PON) | |



16)R43H (TSR): Temperature Sensor Read Register

| R43H | Bit | | | | | | | | | | |
|---------------------------|-----|------|---------|---------|---------|---------|---------|---------|---------|---------|------|
| Inst/Para | R/W | D/CX | D7 | D6 | D5 | D4 | D3 | D2 | D1 | D0 | Code |
| TSR | W | 0 | 0 | 1 | 0 | 0 | 0 | 0 | 1 | 1 | 43H |
| 1 st Parameter | R | 1 | RMSB[7] | RMSB[6] | RMSB[5] | RMSB[4] | RMSB[3] | RMSB[2] | RMSB[1] | RMSB[0] | - |
| 2 nd Parameter | R | 1 | RLSB[7] | RLSB[6] | RLSB[5] | RLSB[4] | RLSB[3] | RLSB[2] | RLSB[1] | RLSB[0] | - |

NOTE: "-" Don't care, can be set to VDD or GND level

| Description | <p>-The command defines as:</p> <p>This command reads the temperature sensed by the temperature sensor.</p> <p>1st Parameter:</p> <table border="1"> <thead> <tr> <th>Bit</th> <th>Name</th> <th>Description</th> </tr> </thead> <tbody> <tr> <td>7-0</td> <td>RMSB[7:0]</td> <td>MSByte of read-data from external temperature sensor</td> </tr> </tbody> </table> <p>2nd Parameter:</p> <table border="1"> <thead> <tr> <th>Bit</th> <th>Name</th> <th>Description</th> </tr> </thead> <tbody> <tr> <td>7-0</td> <td>RLSB[7:0]</td> <td>LSByte of write-data from external temperature sensor</td> </tr> </tbody> </table> | Bit | Name | Description | 7-0 | RMSB[7:0] | MSByte of read-data from external temperature sensor | Bit | Name | Description | 7-0 | RLSB[7:0] | LSByte of write-data from external temperature sensor |
|-------------|--|---|------|-------------|-----|-----------|--|-----|------|-------------|-----|-----------|---|
| Bit | Name | Description | | | | | | | | | | | |
| 7-0 | RMSB[7:0] | MSByte of read-data from external temperature sensor | | | | | | | | | | | |
| Bit | Name | Description | | | | | | | | | | | |
| 7-0 | RLSB[7:0] | LSByte of write-data from external temperature sensor | | | | | | | | | | | |
| Restriction | This command only actives after R04H(PON) | | | | | | | | | | | | |



17)R50H (CDI): VCOM and DATA interval setting Register

| R50H | Bit | | | | | | | | | | |
|---------------------------|-----|------|--------|--------|---------|-----|--------|--------|--------|--------|------|
| Inst/Para | R/W | D/CX | D7 | D6 | D5 | D4 | D3 | D2 | D1 | D0 | Code |
| CDI | W | 0 | 0 | 1 | 0 | 1 | 0 | 0 | 0 | 0 | 50H |
| 1 st Parameter | W | 1 | VBD[2] | VBD[1] | VBD [0] | DDX | CDI[3] | CDI[2] | CDI[1] | CDI[0] | 97h |

NOTE: "-" Don't care, can be set to VDD or GND level

Description -The command defines as:
 This command can set 2 kinds of parameters, 1.VCOM to data output interval(CDI)
 :
CDI[3:0]: This command indicates the interval of VCOM and data output. When setting the vertical back porch, **the total blanking will be keep (55hsync).**

| Bit | Name | Description |
|-----|----------|--|
| 3-0 | CDI[3:0] | Vcom and data interval 0000: 17 hsync 0001: 16 hsync 0010: 15 hsync 0011: 14 hsync 0100: 13 hsync 0101: 12 hsync 0110: 11 hsync 0111: 10 hsync(default) 1000: 9 hsync 1001: 8 hsync 1010: 7 hsync 1011: 6 hsync 1100: 5 hsync 1101: 4 hsync 1110: 3 hsync 1111: 2 hsync |

The timing diagram shows the sequence of signals during a frame transition. It includes:

- Internal vsync**: A pulse indicating the start of a new frame.
- Internal hsync**: Horizontal sync pulses for each line.
- Internal de**: Data enable signal.
- VCOM output**: A signal that remains high during the vertical blanking interval. A note states 'VCOM need to be ready before source data output'.
- Source data Output**: The data for the current frame (Frame N data) and the next frame (Frame N+1 VCOM).
- CDI setting**: A red arrow indicates the duration of the CDI setting, which is the time between the start of VCOM and the start of data output.
- 55 hsync-CDI setting (fixed)**: A dashed line indicates a fixed interval of 55 hsync lines between the start of VCOM and the start of data output.



VBD[2:0]: Border data selection. (from LUT output by IP port border_w[1:0])

This register will make boarder pin output being mapped to a certain gray scale.

| Bit 4 | Bit7-5 | Description | IP setting for Border LUT select |
|-------------|----------|-------------|----------------------------------|
| DDX | VBD[2:0] | Gray level | |
| 0 | 000 | Floating | N/A |
| | 001 | Gray3 | border_buf=011 |
| | 010 | Gray2 | border_buf=010 |
| | 011 | Gray1 | border_buf=001 |
| | 100 | Gray0 | border_buf=000 |
| 1 (default) | 000 | Gray0 | border_buf=000 |
| | 001 | Gray1 | border_buf=001 |
| | 010 | Gray2 | border_buf=010 |
| | 011 | Gray3 | border_buf=011 |
| | 100 | Floating | N/A |

Border output voltage level: The level selection is based on mapping LUT data.

Ex: Gray 1 waveform is mapping to 15V,without VCOM offset, the real output on Boarder pin shall be 15V.

Boarder output will follow FOPT definition being defined in R00h.

Restriction



18) R51H (LPD): Lower Power Detection Register

| R51H | Bit | | | | | | | | | | |
|---------------------------|-----|------|----|----|----|----|----|----|----|-----|------|
| Inst/Para | R/W | D/CX | D7 | D6 | D5 | D4 | D3 | D2 | D1 | D0 | Code |
| LPD | W | 0 | 0 | 1 | 0 | 1 | 0 | 0 | 0 | 1 | 51H |
| 1 st Parameter | R | 1 | - | - | - | - | - | - | - | LPD | - |

NOTE: "-" Don't care, can be set to VDD or GND level

| | | | | | | | |
|-------------|--|-------|-----|---|------------------|---|----------------|
| Description | <p>-The command defines as: This command indicates the input power condition. Host can read this data to understand the battery's condition. When LPD="1", system input power is normal. When LPD="0", system input power is lower (VDD<2.5v, which could be select in RE4H (LVSEL)).</p> <p>1st Parameter:</p> <table border="1"> <tr> <td>Bit 0</td> <td>LPD</td> </tr> <tr> <td>0</td> <td>Low power input.</td> </tr> <tr> <td>1</td> <td>Normal status.</td> </tr> </table> | Bit 0 | LPD | 0 | Low power input. | 1 | Normal status. |
| Bit 0 | LPD | | | | | | |
| 0 | Low power input. | | | | | | |
| 1 | Normal status. | | | | | | |
| Restriction | This command only actives when BUSY_N = "1". | | | | | | |



19)R61H (TRES): Resolution setting

| R61H | Bit | | | | | | | | | | |
|---------------------------|-----|------|---------|---------|---------|---------|---------|---------|---------|---------|------|
| Inst/Para | R/W | D/CX | D7 | D6 | D5 | D4 | D3 | D2 | D1 | D0 | Code |
| TRES | W | 0 | 0 | 1 | 1 | 0 | 0 | 0 | 0 | 1 | 61H |
| 1 st Parameter | W | 1 | - | - | - | - | - | - | HRES(9) | HRES(8) | 00h |
| 2 nd Parameter | W | 1 | HRES(7) | HRES(6) | HRES(5) | HRES(4) | HRES(3) | HRES(2) | 0 | 0 | 00h |
| 3 rd Parameter | W | 1 | - | - | - | - | - | - | VRES(9) | VRES(8) | 00h |
| 4 th Parameter | W | 1 | VRES(7) | VRES(6) | VRES(5) | VRES(4) | VRES(3) | VRES(2) | VRES(1) | VRES(0) | 00h |

NOTE: "-" Don't care, can be set to VDD or GND level

| | |
|-------------|---|
| Description | <p>-The command define as follows: When using register: Horizontal display resolution(source) = HRES Vertical display resolution(gate) = VRES</p> <p>Note: No matter HRES[9:8],HRES[1:0],VRST[9] value being filled, it's always be 00b.</p> <p>Channel disable calculation: GD : First G active = G0; LAST active GD= first active +VRES[9:0] - 1 SD : First active channel: =S0 ; LAST active SD= first active +HRES[9:2]*4-1</p> <p>EX :176X296 GD: First G active = G0 LAST active GD= 0+296-1= 295; (G295) SD : First active channel: =S0 LAST active SD=0+44*4-1=175; (S175)</p> <p>Note : Only supports source 176.ch for source 160ch. above</p> |
| Restriction | Horizontal resolution should be 4-multiple. |



20) R65H(GSST): Gate/Source Start Setting Register

| R65H | Bit | | | | | | | | | | |
|---------------------------|-----|------|------------|------------|------------|------------|------------|------------|------------|------------|------|
| Inst/Para | R/W | D/CX | D7 | D6 | D5 | D4 | D3 | D2 | D1 | D0 | Code |
| GSST | W | 0 | 0 | 1 | 1 | 0 | 0 | 1 | 0 | 1 | 65H |
| 1 st Parameter | W | 1 | - | - | - | - | - | - | S_start[9] | S_start[8] | 00h |
| 2 nd Parameter | W | 1 | S_start[7] | S_start[6] | S_start[5] | S_start[4] | S_start[3] | S_start[2] | 0 | 0 | 00h |
| 3 rd Parameter | W | 1 | - | - | - | - | - | - | G_start[9] | G_start[8] | 00h |
| 4 th Parameter | W | 1 | G_start[7] | G_start[6] | G_start[6] | G_start[4] | G_start[3] | G_start[2] | G_start[1] | G_start[0] | 00h |

NOTE: "-" Don't care, can be set to VDD or GND level

| | |
|-------------|---|
| Description | -The command define as follows: Note: No matter S_start[9:8], S_start [1:0], VRST[9] value being filled, it's always be 00b. |
| | 1.S_Start [7:0] describe which source output line is the first date line 2.G_Start[8:0] describe which gate line is the first scan line |
| Restriction | S_Start should be the multiple of 4 |

21)R70H (REV): REVISION register

| R70H | Bit | | | | | | | | | | |
|---------------------------|-----|------|----|----|----|----|----|----|----|----|------|
| Inst/Para | R/W | D/CX | D7 | D6 | D5 | D4 | D3 | D2 | D1 | D0 | Code |
| REV | W | 0 | 0 | 1 | 1 | 1 | 0 | 0 | 0 | 0 | 70H |
| 1 st Parameter | R | 1 | 0 | 0 | 0 | 0 | 0 | 0 | 1 | 1 | 03h |
| 2 nd Parameter | R | 1 | 0 | 0 | 0 | 0 | 0 | 0 | 1 | 0 | 02h |
| 3 rd Parameter | R | 1 | 0 | 0 | 0 | 0 | 0 | 0 | 0 | 1 | 01h |

NOTE: "-" Don't care, can be set to VDD or GND level

| Description | -The command defines as: 1 st & 2 nd & 3 rd Parameter: | | | |
|-------------|--|-----|-------------|-----|
| | <table border="1"> <thead> <tr> <th>Bit</th> <th>Description</th> </tr> </thead> <tbody> <tr> <td>7-0</td> <td>CHIP_REV</td> </tr> </tbody> </table> | Bit | Description | 7-0 |
| Bit | Description | | | |
| 7-0 | CHIP_REV | | | |
| Restriction | | | | |



22)R80H (AMV): Auto Measure VCOM register

| R80H | Bit | | | | | | | | | | |
|---------------------------|-----|------|------|------|---------|---------|-----|------|-----|------|------|
| Inst/Para | R/W | D/CX | D7 | D6 | D5 | D4 | D3 | D2 | D1 | D0 | Code |
| AMV | W | 0 | 1 | 0 | 0 | 0 | 0 | 0 | 0 | 0 | 80H |
| 1 st Parameter | W | 1 | P[1] | P[0] | AMVT[1] | AMVT[0] | XON | AMVS | AMV | AMVE | 00h |

NOTE: "-" Don't care, can be set to VDD or GND level

| Description | <p>-The command defines as: This command indicates the IC status. Host can read this data to understand the IC status.</p> <p>1st Parameter:</p> <table border="1"> <thead> <tr> <th>Bit</th> <th>Name</th> <th>Description</th> </tr> </thead> <tbody> <tr> <td>0</td> <td>AMVE</td> <td>AMVE: Auto Measure Vcom Setting 0: Auto measure VCOM disable (default) 1: Auto measure VCOM enable</td> </tr> <tr> <td>1</td> <td>AMV</td> <td>AMV: Analog signal 0: Get Vcom value from R81h(default) 1: Get Vcom value in analog signal</td> </tr> <tr> <td>2</td> <td>AMVS</td> <td>AMVS: setting for Source output of AMV 0: Source output 0V during Auto Measure VCOM period. (default) 1: Source output VSPL_0 during Auto Measure VCOM period.</td> </tr> <tr> <td>3</td> <td>XON</td> <td>XON: setting for all Gate ON of AMV 0: Gate normally scan during Auto Measure VCOM period. (default) 1: All Gate ON during Auto Measure VCOM period.</td> </tr> <tr> <td>5-4</td> <td>AMVT[1:0]</td> <td>The sensing time of VCOM detection 00: 5s (default) 01: 10s 10: 15s 11: 20s</td> </tr> <tr> <td>7-6</td> <td>P[1:0]</td> <td>The sensing points of sampling time 00: 2 (default) 01: 4 10: 8 11: 16 Sampling time = the last quarter of sensing time (T) VCOM = average of N points. N=2,4,8,16</td> </tr> </tbody> </table> | | | | | | | | | | | Bit | Name | Description | 0 | AMVE | AMVE: Auto Measure Vcom Setting 0: Auto measure VCOM disable (default) 1: Auto measure VCOM enable | 1 | AMV | AMV: Analog signal 0: Get Vcom value from R81h(default) 1: Get Vcom value in analog signal | 2 | AMVS | AMVS: setting for Source output of AMV 0: Source output 0V during Auto Measure VCOM period. (default) 1: Source output VSPL_0 during Auto Measure VCOM period. | 3 | XON | XON: setting for all Gate ON of AMV 0: Gate normally scan during Auto Measure VCOM period. (default) 1: All Gate ON during Auto Measure VCOM period. | 5-4 | AMVT[1:0] | The sensing time of VCOM detection 00: 5s (default) 01: 10s 10: 15s 11: 20s | 7-6 | P[1:0] | The sensing points of sampling time 00: 2 (default) 01: 4 10: 8 11: 16 Sampling time = the last quarter of sensing time (T) VCOM = average of N points. N=2,4,8,16 |
|-------------|--|---|-------------|--|--|--|--|--|--|--|--|-----|------|-------------|---|------|--|---|-----|--|---|------|--|---|-----|--|-----|-----------|---|-----|--------|---|
| | Bit | Name | Description | | | | | | | | | | | | | | | | | | | | | | | | | | | | | |
| 0 | AMVE | AMVE: Auto Measure Vcom Setting 0: Auto measure VCOM disable (default) 1: Auto measure VCOM enable | | | | | | | | | | | | | | | | | | | | | | | | | | | | | | |
| 1 | AMV | AMV: Analog signal 0: Get Vcom value from R81h(default) 1: Get Vcom value in analog signal | | | | | | | | | | | | | | | | | | | | | | | | | | | | | | |
| 2 | AMVS | AMVS: setting for Source output of AMV 0: Source output 0V during Auto Measure VCOM period. (default) 1: Source output VSPL_0 during Auto Measure VCOM period. | | | | | | | | | | | | | | | | | | | | | | | | | | | | | | |
| 3 | XON | XON: setting for all Gate ON of AMV 0: Gate normally scan during Auto Measure VCOM period. (default) 1: All Gate ON during Auto Measure VCOM period. | | | | | | | | | | | | | | | | | | | | | | | | | | | | | | |
| 5-4 | AMVT[1:0] | The sensing time of VCOM detection 00: 5s (default) 01: 10s 10: 15s 11: 20s | | | | | | | | | | | | | | | | | | | | | | | | | | | | | | |
| 7-6 | P[1:0] | The sensing points of sampling time 00: 2 (default) 01: 4 10: 8 11: 16 Sampling time = the last quarter of sensing time (T) VCOM = average of N points. N=2,4,8,16 | | | | | | | | | | | | | | | | | | | | | | | | | | | | | | |
| Restriction | This command only actives when BUSY_N = "1". | | | | | | | | | | | | | | | | | | | | | | | | | | | | | | | |

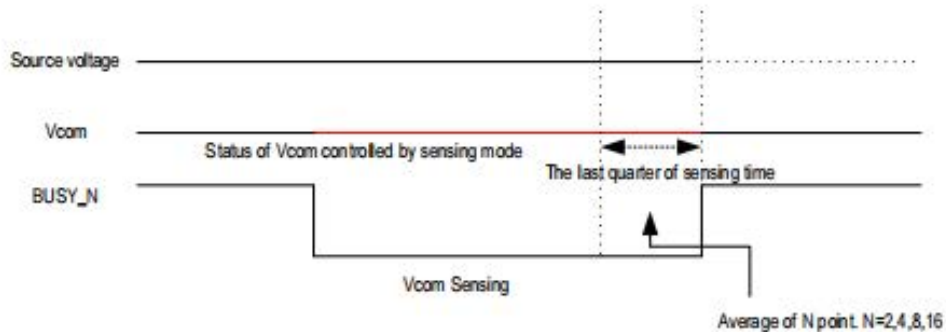



23)R81H (VV): VCOM Value register

| R81H | Bit | | | | | | | | | | |
|---------------------------|-----|------|----|-------|-------|-------|-------|-------|-------|-------|------|
| Inst/Para | R/W | D/CX | D7 | D6 | D5 | D4 | D3 | D2 | D1 | D0 | Code |
| VV | W | 0 | 1 | 0 | 0 | 0 | 0 | 0 | 0 | 1 | 81H |
| 1 st Parameter | R | 1 | - | VV[6] | VV[5] | VV[4] | VV[3] | VV[2] | VV[1] | VV[0] | -- |

NOTE: "-" Don't care, can be set to VDD or GND level

| | | | | | | | | | | | |
|-------------|---|---------|-------------|-----------|------------|-----------|------------|-----------|------------|-----------|------------|
| Description | -The command defines as: This command could get the VCOM value | | | | | | | | | | |
| | 1 st Parameter: | | | | | | | | | | |
| | Bit | Name | Description | | | | | | | | |
| | 6-0 | VV[6:0] | VCOM value | | | | | | | | |
| VCOM[6:0] | | | Voltage(V) | VCOM[6:0] | Voltage(V) | VCOM[6:0] | Voltage(V) | VCOM[6:0] | Voltage(V) | VCOM[6:0] | Voltage(V) |
| | | | 0000000 | 00h | 0 | 0011100 | 1Ch | -1.4 | 0111000 | 38h | -2.8 |
| | | | 0000001 | 01h | -0.05 | 0011101 | 1Dh | -1.45 | 0111001 | 39h | -2.85 |
| | | | 0000010 | 02h | -0.1 | 0011110 | 1Eh | -1.5 | 0111010 | 3Ah | -2.9 |
| | | | 0000011 | 03h | -0.15 | 0011111 | 1Fh | -1.55 | 0111011 | 3Bh | -2.95 |
| | | | 0000100 | 04h | -0.2 | 0100000 | 20h | -1.6 | 0111100 | 3Ch | -3 |
| | | | 0000101 | 05h | -0.25 | 0100001 | 21h | -1.65 | 0111101 | 3Dh | -3.05 |
| | | | 0000110 | 06h | -0.3 | 0100010 | 22h | -1.7 | 0111110 | 3Eh | -3.1 |
| | | | 0000111 | 07h | -0.35 | 0100011 | 23h | -1.75 | 0111111 | 3Fh | -3.15 |
| | | | 0001000 | 08h | -0.4 | 0100100 | 24h | -1.8 | 1000000 | 40h | -3.2 |
| | | | 0001001 | 09h | -0.45 | 0100101 | 25h | -1.85 | 1000001 | 41h | -3.25 |
| | | | 0001010 | 0Ah | -0.5 | 0100110 | 26h | -1.9 | 1000010 | 42h | -3.3 |
| | | | 0001011 | 0Bh | -0.55 | 0100111 | 27h | -1.95 | 1000011 | 43h | -3.35 |
| | | | 0001100 | 0Ch | -0.6 | 0101000 | 28h | -2 | 1000100 | 44h | -3.4 |
| | | | 0001101 | 0Dh | -0.65 | 0101001 | 29h | -2.05 | 1000101 | 45h | -3.45 |
| | | | 0001110 | 0Eh | -0.7 | 0101010 | 2Ah | -2.1 | 1000110 | 46h | -3.5 |
| | | | 0001111 | 0Fh | -0.75 | 0101011 | 2Bh | -2.15 | 1000111 | 47h | -3.55 |
| | | | 0010000 | 10h | -0.8 | 0101100 | 2Ch | -2.2 | 1001000 | 48h | -3.6 |
| | | | 0010001 | 11h | -0.85 | 0101101 | 2Dh | -2.25 | 1001001 | 49h | -3.65 |
| | | | 0010010 | 12h | -0.9 | 0101110 | 2Eh | -2.3 | 1001010 | 4Ah | -3.7 |
| | | | 0010011 | 13h | -0.95 | 0101111 | 2Fh | -2.35 | 1001011 | 4Bh | -3.75 |
| | | | 0010100 | 14h | -1 | 0110000 | 30h | -2.4 | 1001100 | 4Ch | -3.8 |
| | | | 0010101 | 15h | -1.05 | 0110001 | 31h | -2.45 | 1001101 | 4Dh | -3.85 |
| | | | 0010110 | 16h | -1.1 | 0110010 | 32h | -2.5 | 1001110 | 4Eh | -3.9 |
| | | | 0010111 | 17h | -1.15 | 0110011 | 33h | -2.55 | 1001111 | 4Fh | -3.95 |
| | | | 0011000 | 18h | -1.2 | 0110100 | 34h | -2.6 | 1010000 | 50h | -4 |
| | | | 0011001 | 19h | -1.25 | 0110101 | 35h | -2.65 | other | | -4 |
| | | | 0011010 | 1Ah | -1.3 | 0110110 | 36h | -2.7 | | | |
| | | | 0011011 | 1Bh | -1.35 | 0110111 | 37h | -2.75 | | | |
| Restriction | | | | | | | | | | | |



24)R82H (VDCS): VCOM_DC Setting Register

| R82H | Bit | | | | | | | | | | |
|---------------------------|-----|------|-------------|---------|---------|---------|---------|---------|---------|---------|------|
| Inst/Para | R/W | D/CX | D7 | D6 | D5 | D4 | D3 | D2 | D1 | D0 | Code |
| VDCS | W | 0 | 1 | 0 | 0 | 0 | 0 | 0 | 1 | 0 | 82H |
| 1 st Parameter | W | 1 | MTP_VC M | VDCS[6] | VDCS[5] | VDCS[4] | VDCS[3] | VDCS[2] | VDCS[1] | VDCS[0] | 00h |

NOTE: "-" Don't care, can be set to VDD or GND level

| | | | | | | | | | | | |
|-------------|--|------|-------------|------------|------------|------------|-----------|------------|---------|-----|-------|
| Description | -The command defines as: This command set the VCOM DC value. Driver will base on this value for VCM_DC. | | | | | | | | | | |
| | 1st Parameter: | | | | | | | | | | |
| | Bit | Name | Description | | | | | | | | |
| | | | VCOM value | | | | | | | | |
| | | | VCOM[6:0] | Voltage(V) | VCOM[6:0] | Voltage(V) | VCOM[6:0] | Voltage(V) | | | |
| | | | 0000000 | 00h | 0(default) | 0011100 | 1Ch | -1.4 | 0111000 | 38h | -2.8 |
| | | | 0000001 | 01h | -0.05 | 0011101 | 1Dh | -1.45 | 0111001 | 39h | -2.85 |
| | | | 0000010 | 02h | -0.1 | 0011110 | 1Eh | -1.5 | 0111010 | 3Ah | -2.9 |
| | | | 0000011 | 03h | -0.15 | 0011111 | 1Fh | -1.55 | 0111011 | 3Bh | -2.95 |
| | | | 0000100 | 04h | -0.2 | 0100000 | 20h | -1.6 | 0111100 | 3Ch | -3 |
| | | | 0000101 | 05h | -0.25 | 0100001 | 21h | -1.65 | 0111101 | 3Dh | -3.05 |
| | | | 0000110 | 06h | -0.3 | 0100010 | 22h | -1.7 | 0111110 | 3Eh | -3.1 |
| | | | 0000111 | 07h | -0.35 | 0100011 | 23h | -1.75 | 0111111 | 3Fh | -3.15 |
| | | | 0001000 | 08h | -0.4 | 0100100 | 24h | -1.8 | 1000000 | 40h | -3.2 |
| | | | 0001001 | 09h | -0.45 | 0100101 | 25h | -1.85 | 1000001 | 41h | -3.25 |
| | | | 0001010 | 0Ah | -0.5 | 0100110 | 26h | -1.9 | 1000010 | 42h | -3.3 |
| | | | 0001011 | 0Bh | -0.55 | 0100111 | 27h | -1.95 | 1000011 | 43h | -3.35 |
| | | | 0001100 | 0Ch | -0.6 | 0101000 | 28h | -2 | 1000100 | 44h | -3.4 |
| | | | 0001101 | 0Dh | -0.65 | 0101001 | 29h | -2.05 | 1000101 | 45h | -3.45 |
| | | | 0001110 | 0Eh | -0.7 | 0101010 | 2Ah | -2.1 | 1000110 | 46h | -3.5 |
| | | | 0001111 | 0Fh | -0.75 | 0101011 | 2Bh | -2.15 | 1000111 | 47h | -3.55 |
| | | | 0010000 | 10h | -0.8 | 0101100 | 2Ch | -2.2 | 1001000 | 48h | -3.6 |
| | | | 0010001 | 11h | -0.85 | 0101101 | 2Dh | -2.25 | 1001001 | 49h | -3.65 |
| | | | 0010010 | 12h | -0.9 | 0101110 | 2Eh | -2.3 | 1001010 | 4Ah | -3.7 |
| | | | 0010011 | 13h | -0.95 | 0101111 | 2Fh | -2.35 | 1001011 | 4Bh | -3.75 |
| | | | 0010100 | 14h | -1 | 0110000 | 30h | -2.4 | 1001100 | 4Ch | -3.8 |
| | | | 0010101 | 15h | -1.05 | 0110001 | 31h | -2.45 | 1001101 | 4Dh | -3.85 |
| | | | 0010110 | 16h | -1.1 | 0110010 | 32h | -2.5 | 1001110 | 4Eh | -3.9 |
| | | | 0010111 | 17h | -1.15 | 0110011 | 33h | -2.55 | 1001111 | 4Fh | -3.95 |
| | | | 0011000 | 18h | -1.2 | 0110100 | 34h | -2.6 | 1010000 | 50h | -4 |
| | | | 0011001 | 19h | -1.25 | 0110101 | 35h | -2.65 | other | | -4 |
| | | | 0011010 | 1Ah | -1.3 | 0110110 | 36h | -2.7 | | | |
| | | | 0011011 | 1Bh | -1.35 | 0110111 | 37h | -2.75 | | | |



| | | | |
|-------------|---|---------|--|
| | 7 | MTP_VCM | Follow MTP VCOM value in MTP mode 0: From the setting of MTP (default) 1: From the setting of register |
| Restriction | | | |

25) R83H (PTL): Partial Window Register

| R83H | Bit | | | | | | | | | | |
|---------------------------|-----|------|---------|---------|---------|---------|---------|---------|---------|---------|------|
| Inst/Para | R/W | D/CX | D7 | D6 | D5 | D4 | D3 | D2 | D1 | D0 | Code |
| PTL | W | 0 | 1 | 0 | 0 | 0 | 0 | 0 | 1 | 1 | 83H |
| 1 st Parameter | W | 1 | - | - | - | - | - | - | HRST[9] | HRST[8] | 00h |
| 2 nd Parameter | W | 1 | HRST[7] | HRST[6] | HRST[5] | HRST[4] | HRST[3] | HRST[2] | - | - | 00h |
| 3 rd Parameter | W | 1 | - | - | - | - | - | - | HRED[9] | HRED[8] | 00h |
| 4 th Parameter | W | 1 | HRED[7] | HRED[6] | HRED[5] | HRED[4] | HRED[3] | HRED[2] | - | - | 00h |
| 5 th Parameter | W | 1 | - | - | - | - | - | - | VRST[9] | VRST[8] | 00h |
| 6 th Parameter | W | 1 | VRST[7] | VRST[6] | VRST[5] | VRST[4] | VRST[3] | VRST[2] | VRST[1] | VRST[0] | 00h |
| 7 th Parameter | W | 1 | - | - | - | - | - | - | VRED[9] | VRED[8] | 00h |
| 8 th Parameter | W | 1 | VRED[7] | VRED[6] | VRED[5] | VRED[4] | VRED[3] | VRED[2] | VRED[1] | VRED[0] | 00h |
| 9 th Parameter | W | 1 | - | - | - | - | - | - | - | PMODE | 00h |

NOTE: "-" Don't care, can be set to VDD or GND level

| Description | -This command sets partial window. | | | | | | | | | | | |
|-------------|--|------|-------------|-----------|--------------------------|-----------|---|-----------|-------------------------|-----------|---|-------|
| | <table border="1"> <thead> <tr> <th>Name</th> <th>Description</th> </tr> </thead> <tbody> <tr> <td>HRST[9:2]</td> <td>Horizontal start address</td> </tr> <tr> <td>HRED[9:2]</td> <td>Horizontal end address. HRED must be greater than HRST.</td> </tr> <tr> <td>VRST[9:0]</td> <td>Vertical start address.</td> </tr> <tr> <td>VRED[9:0]</td> <td>Vertical end address. VRED must be greater than VRST.</td> </tr> <tr> <td>PMODE</td> <td>0: disable partial mode (default) 1: enable partial mode</td> </tr> </tbody> </table> <p>Note: No matter HRST[1:0], HRST[9:8], HRED[9:8], VRST[9], VRED[9] value being filled, it's always be 00b. No matter HRED[1:0] value being filled, it's always be 11b.</p> <p>Gates scan both inside and outside of the partial window.</p> | Name | Description | HRST[9:2] | Horizontal start address | HRED[9:2] | Horizontal end address. HRED must be greater than HRST. | VRST[9:0] | Vertical start address. | VRED[9:0] | Vertical end address. VRED must be greater than VRST. | PMODE |
| Name | Description | | | | | | | | | | | |
| HRST[9:2] | Horizontal start address | | | | | | | | | | | |
| HRED[9:2] | Horizontal end address. HRED must be greater than HRST. | | | | | | | | | | | |
| VRST[9:0] | Vertical start address. | | | | | | | | | | | |
| VRED[9:0] | Vertical end address. VRED must be greater than VRST. | | | | | | | | | | | |
| PMODE | 0: disable partial mode (default) 1: enable partial mode | | | | | | | | | | | |
| Restriction | | | | | | | | | | | | |



26) R90H (PGM): Program Mode

| R90H | Bit | | | | | | | | | | |
|-----------|-----|------|----|----|----|----|----|----|----|----|------|
| Inst/Para | R/W | D/CX | D7 | D6 | D5 | D4 | D3 | D2 | D1 | D0 | Code |
| PGM | W | 0 | 1 | 0 | 0 | 1 | 0 | 0 | 0 | 0 | 90H |

NOTE: "-" Don't care, can be set to VDD or GND level

| | |
|-------------|--|
| Description | -The command define as follows: After this command is issued, the chip would enter the program mode. The mode would return to standby by hardware reset. |
| Restriction | |

27)R91H (APG): Active Program

| R91H | Bit | | | | | | | | | | |
|-----------|-----|------|----|----|----|----|----|----|----|----|------|
| Inst/Para | R/W | D/CX | D7 | D6 | D5 | D4 | D3 | D2 | D1 | D0 | Code |
| APG | W | 0 | 1 | 0 | 0 | 1 | 0 | 0 | 0 | 1 | 91H |

NOTE: "-" Don't care, can be set to VDD or GND level

| | |
|-------------|---|
| Description | -The command define as follows: After this command is transmitted, the programming state machine would be activated. |
| Restriction | The BUSY flag would change state from 0 to 1 while the programming is completed. |

28)R92H (RMTP): Read MTP Data

| R92H | Bit | | | | | | | | | | |
|--|-----|------|--------------------------------------|----|----|----|----|----|----|----|------|
| Inst/Para | R/W | D/CX | D7 | D6 | D5 | D4 | D3 | D2 | D1 | D0 | Code |
| RMTP | W | 0 | 1 | 0 | 0 | 1 | 0 | 0 | 1 | 0 | 92H |
| 1 st Parameter | R | 1 | Dummy | | | | | | | | - |
| 2 nd Parameter | R | 1 | The data of address 0x000 in the MTP | | | | | | | | - |
| 3 rd Parameter | R | 1 | The data of address 0x001 in the MTP | | | | | | | | - |
| 4 th Parameter | R | 1 | : | | | | | | | | - |
| 5 th Parameter | R | 1 | The data of address (n-1) in the MTP | | | | | | | | - |
| 6 th ~(m-1) th Parameter | R | 1 | | | | | | | | | - |
| m th Parameter | R | 1 | The data of address (n) in the MTP | | | | | | | | - |

NOTE: "-" Don't care, can be set to VDD or GND level

| | |
|-------------|---|
| Description | -The command define as follows: The command is used for reading the content of MTP for checking the data of programming. The value of (n) is depending on the amount of programmed data, the max address = 0x17FF |
|-------------|---|

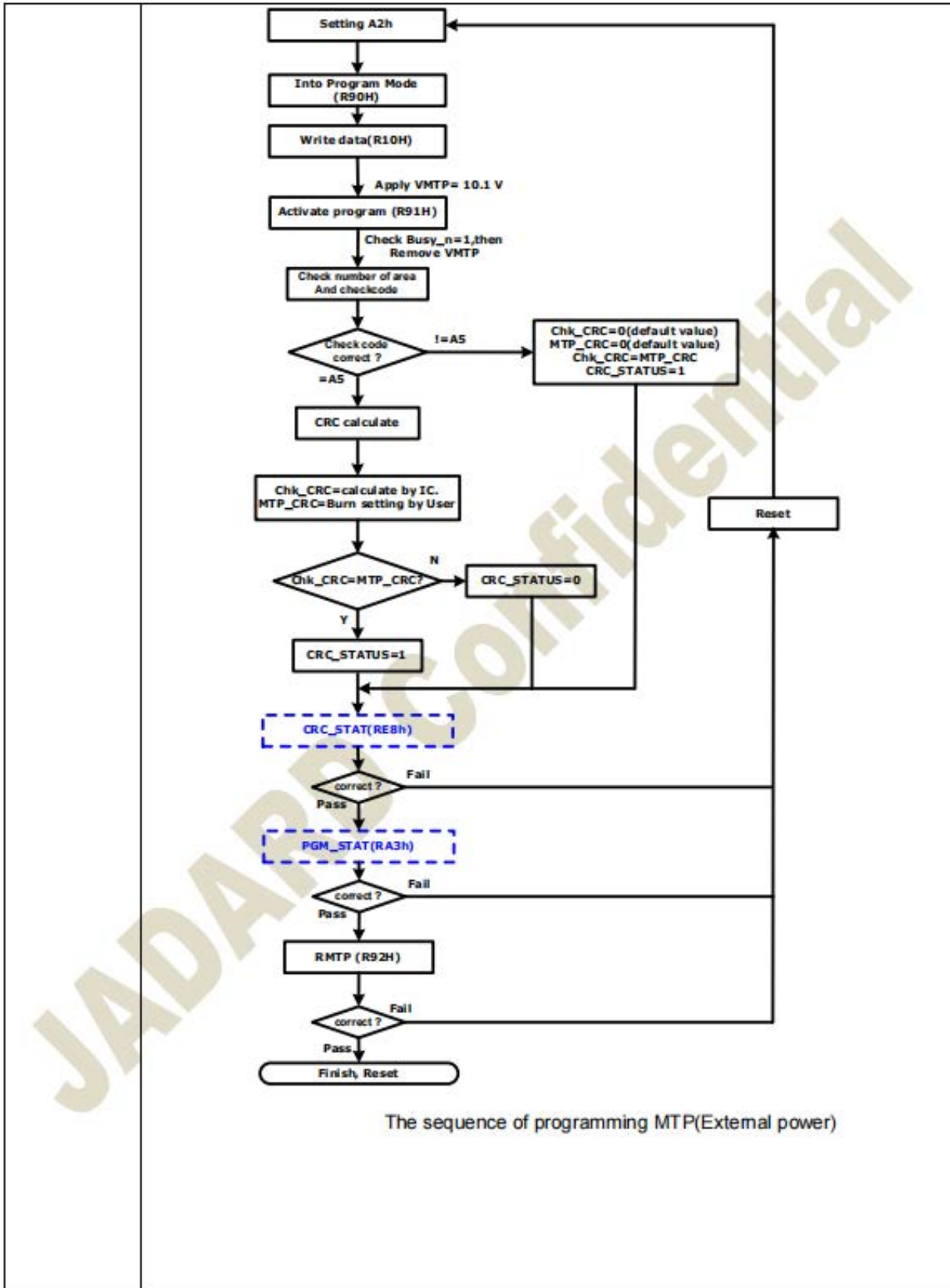

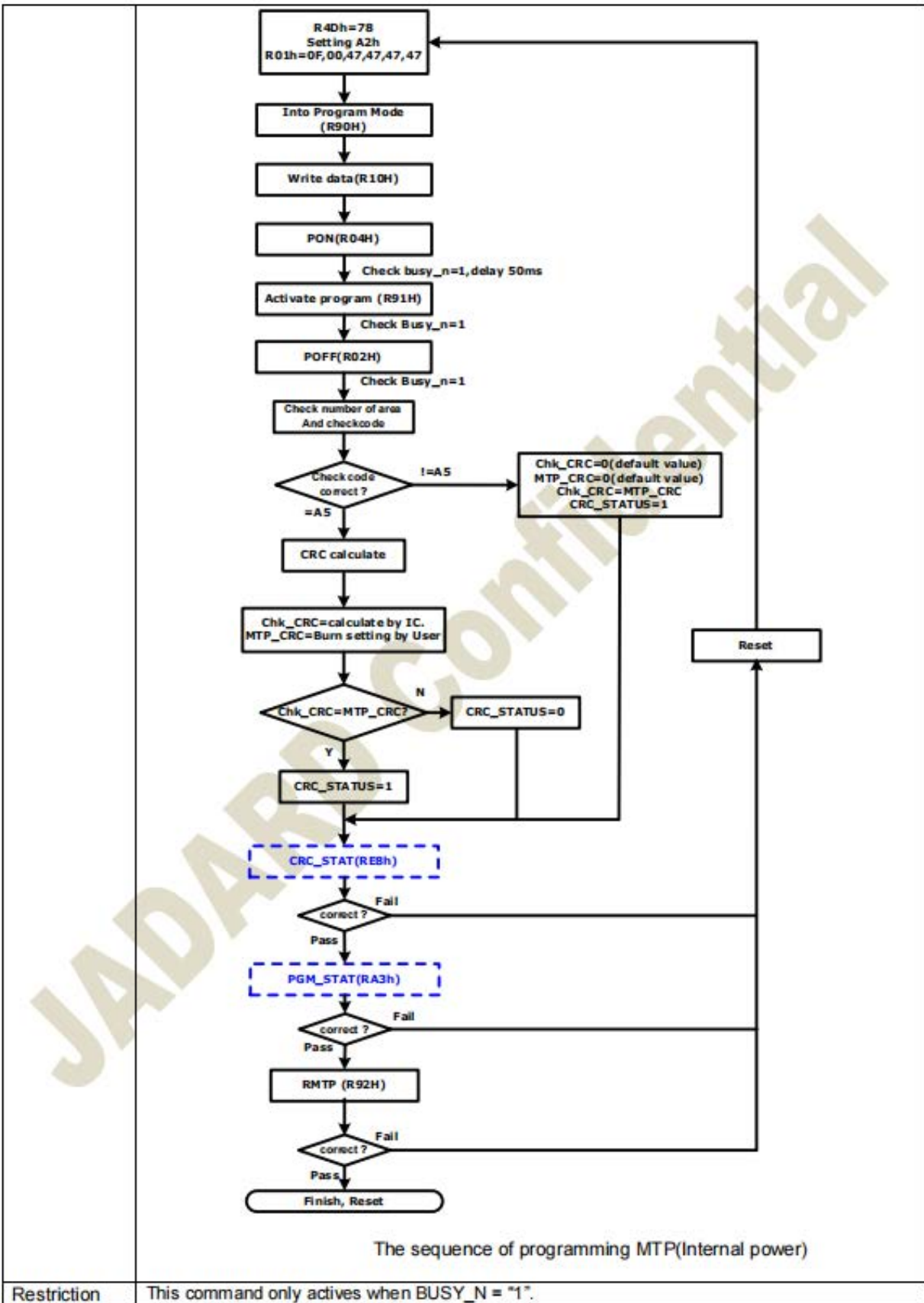

Restriction This command only activates when BUSY_N = "1".



29)R9EH(REV2): REVISION2 register

| R9EH | Bit | | | | | | | | | | |
|---------------------------|-----|------|----|----|----|----|----|----|----|----|------|
| Inst/Para | R/W | D/CX | D7 | D6 | D5 | D4 | D3 | D2 | D1 | D0 | Code |
| REV2 | W | 0 | 1 | 0 | 0 | 1 | 1 | 1 | 1 | 0 | 9EH |
| 1 st Parameter | R | 1 | 0 | 0 | 0 | 0 | 0 | 0 | 0 | 1 | 01h |

| | | |
|-------------|----------------------------|-------------|
| Description | -The command defines as: | |
| | 1 st Parameter: | |
| | Bit | Description |
| | 7-0 | CHIP_REV |
| Restriction | | |

30) R9FH(RMRB) Read MTP Reserved Bytes

| R9FH | Bit | | | | | | | | | | |
|-----------------------------|-----|------|---------------------------------------|----|----|----|----|----|----|----|------|
| Inst/Para | R/W | D/CX | D7 | D6 | D5 | D4 | D3 | D2 | D1 | D0 | Code |
| RMRB | W | 0 | 1 | 0 | 0 | 1 | 1 | 1 | 1 | 1 | 9FH |
| 1 st Parameter | R | 1 | Dummy | | | | | | | | 00h |
| 2 nd Parameter | R | 1 | The data of address 0x16F7 in the MTP | | | | | | | | 00h |
| 3 rd Parameter | R | 1 | : | | | | | | | | 00h |
| : | R | 1 | : | | | | | | | | 00h |
| 97 th Parameter | R | 1 | : | | | | | | | | 00h |
| 98 th Parameter | R | 1 | : | | | | | | | | 00h |
| 101 th Parameter | R | 1 | The data of address 0x175A in the MTP | | | | | | | | 00h |

| | | |
|-------------|--|--|
| Description | -The command define as follows: | |
| | The command is used for reading the content of MTP Reserved Byte for checking the data of programming. | |
| | This command could read these information from MTP directly. | |
| Restriction | | |



31) RE3H (PWS): Power Saving Register

| RE3H | Bit | | | | | | | | | | |
|---------------------------|-----|------|-------------|----|----|----|-----------|----|----|----|------|
| Inst/Para | R/W | D/CX | D7 | D6 | D5 | D4 | D3 | D2 | D1 | D0 | Code |
| PWS | W | 0 | 1 | 1 | 1 | 0 | 0 | 0 | 1 | 1 | E3H |
| 1 st Parameter | W | 1 | VCOM_W[3:0] | | | | SD_W[3:0] | | | | 00h |

NOTE: "-" Don't care, can be set to VDD or GND level

Description

- This command is set for saving power during refreshing period. If the output voltage of VCOM / Source is from negative to positive or from positive to negative, the power saving mechanism will be activated. The active period width is defined by the following two parameters.

VCOM_W: VCOM power saving width (unit = line period)

SD_W: Source power saving width (unit = 500nS), SD_W ≤ S2G

Restriction

32) RE4H (LVSEL): LVD Voltage Select Register

| RE4H | Bit | | | | | | | | | | |
|---------------------------|-----|------|----|----|----|----|----|----|--------------|----|------|
| Inst/Para | R/W | D/CX | D7 | D6 | D5 | D4 | D3 | D2 | D1 | D0 | Code |
| LVSEL | W | 0 | 1 | 1 | 1 | 0 | 0 | 1 | 0 | 0 | E4H |
| 1 st Parameter | W | 1 | - | - | - | - | - | - | LVD_SEL[1:0] | | 03h |

NOTE: "-" Don't care, can be set to VDD or GND level

| | | |
|--------------------|---|-------------------|
| Description | LVD_SEL[1:0]: Low Power Voltage Selection | |
| | LVD_SEL[1:0] | LVD value |
| | 00 | < 2.2 V |
| | 01 | < 2.3 V |
| | 10 | < 2.4 V |
| | 11 | < 2.5 V (default) |
| Restriction | | |

8. Block Diagram

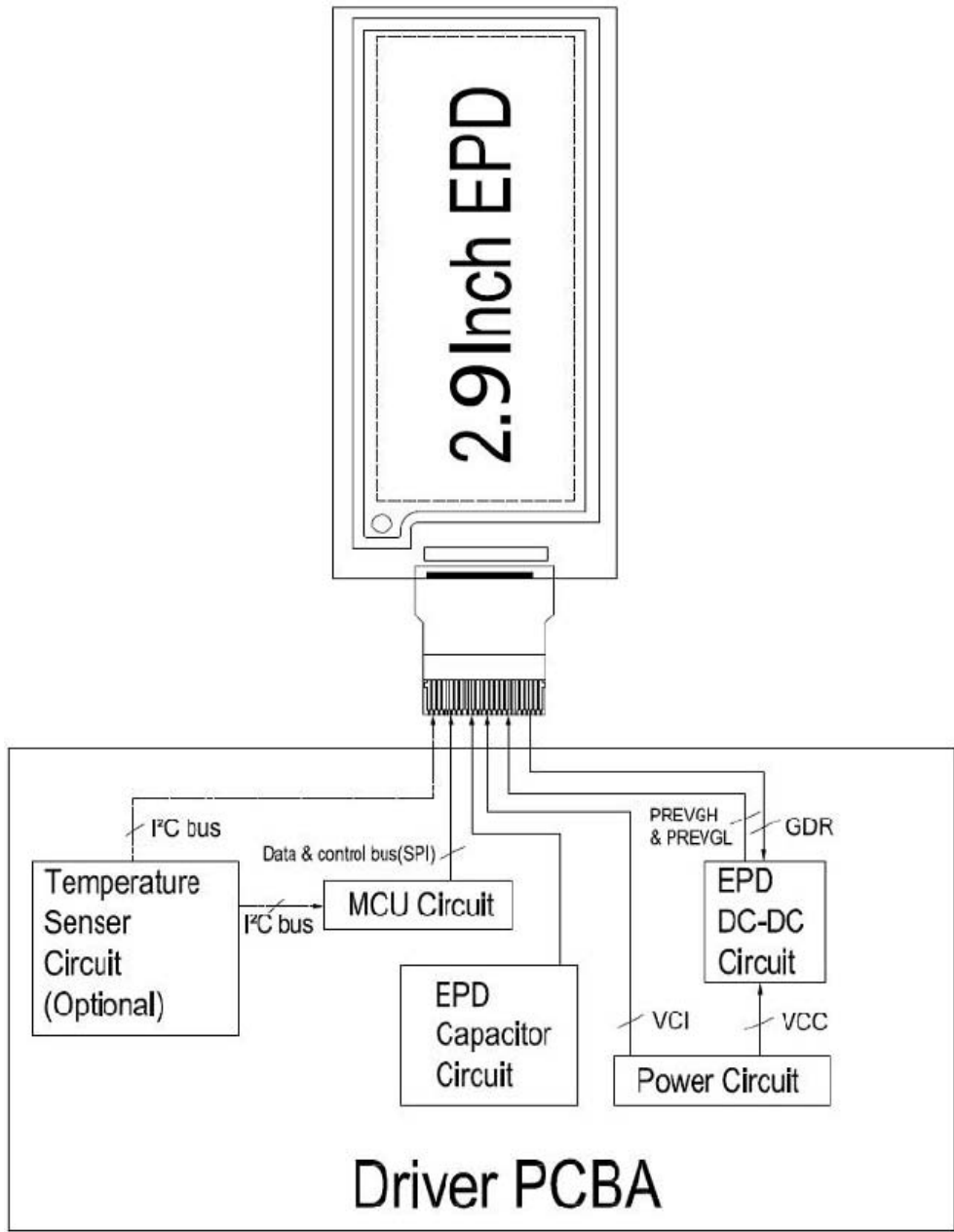



9. Typical Application Circuit with SPI Interface

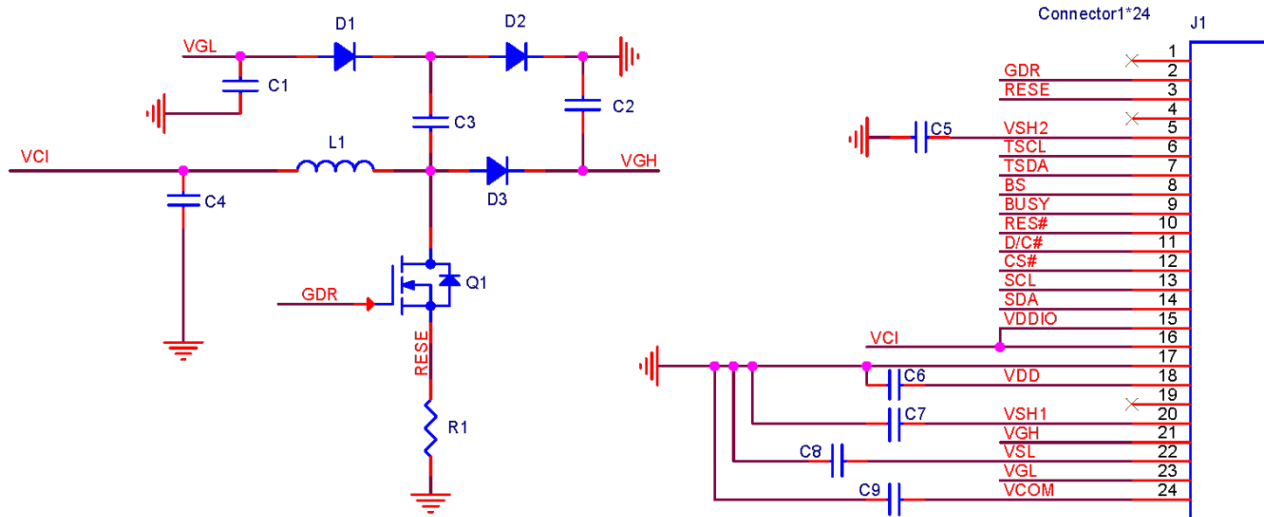

| Part Name | Value | Reference Part |
|--------------------|-------|-----------------------|
| C1 C4 C5 C6 C7C8C9 | 1uF | Voltage Rating:25v |
| C2 C3 | 1uF | Voltage Rating:50v |
| R1 | 2.2Ω | 0603, +/-1% variation |
| D1 D2 D3 | Diode | MBR0530 |
| Q1 | NMOS | Si1308EDL、Si1304BDL |
| L1 | 47UH | CDRH2D18/LDNP-470NC |

10 Typical Operating Sequence

10.1 LUT from OTP Operation Flow

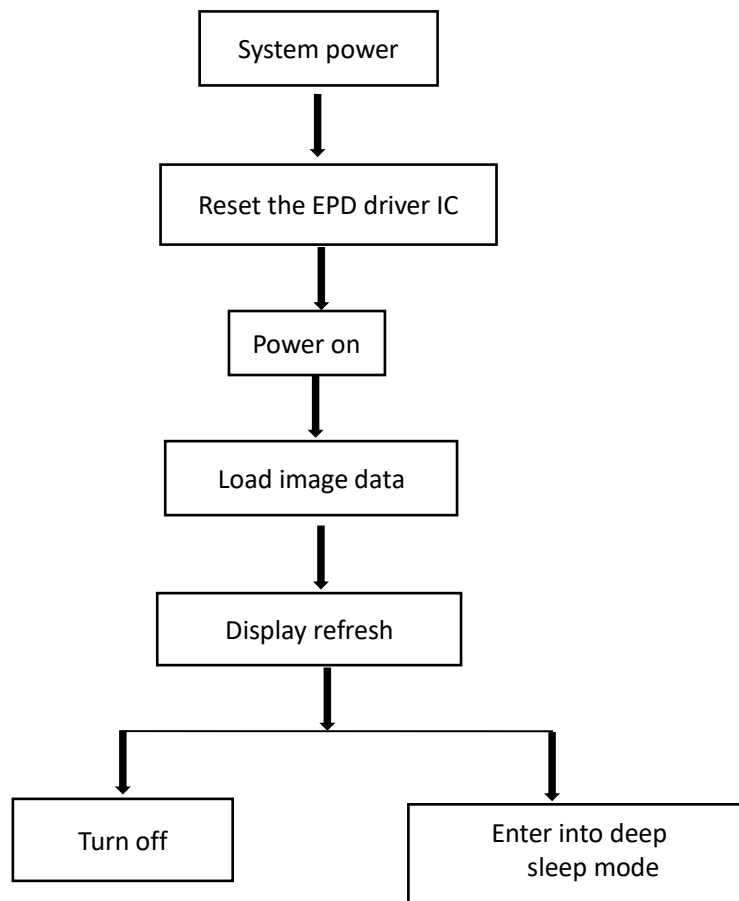



10.2 OTP Operation Reference Program Code

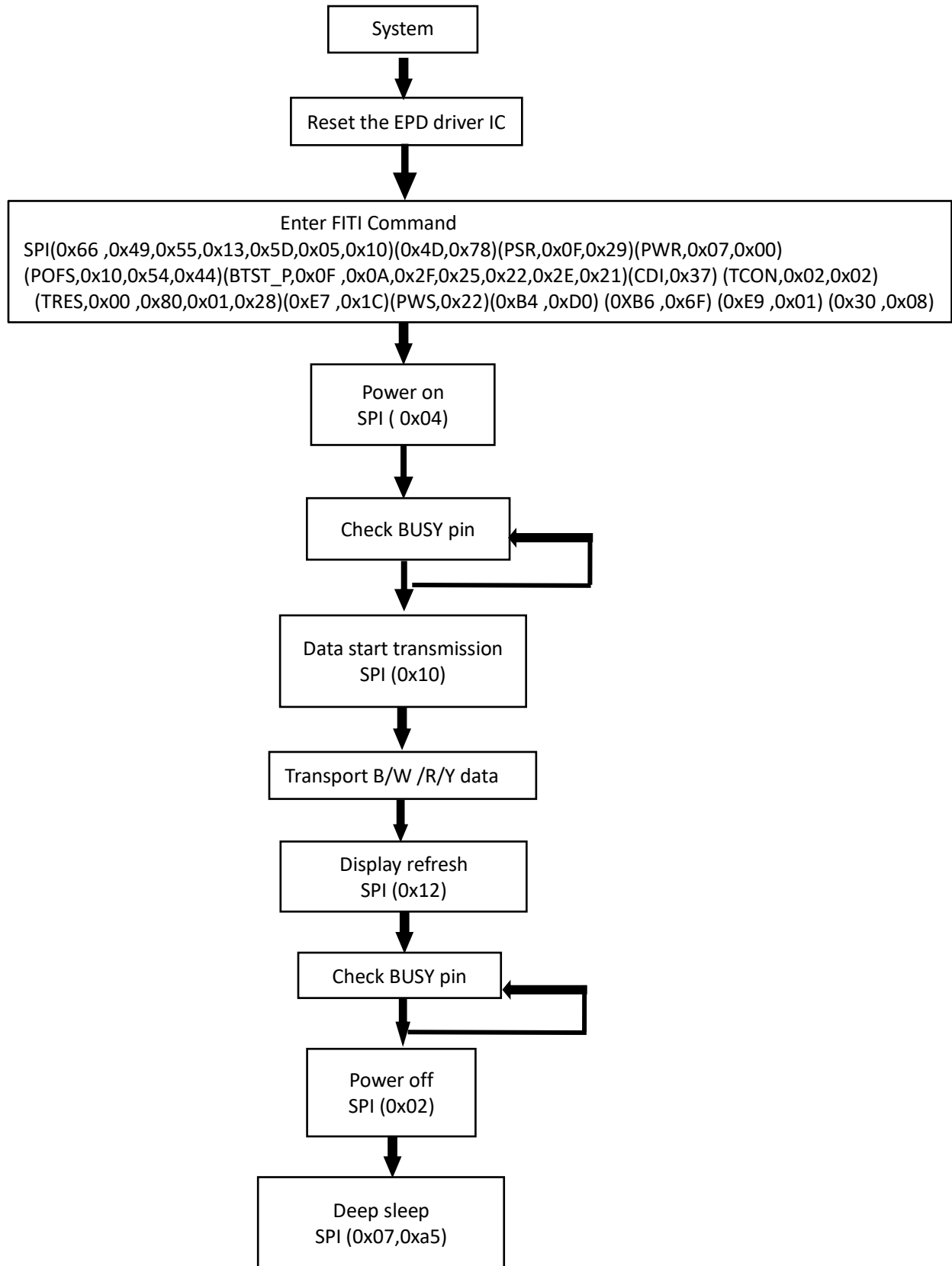



11. Reliability Test

| NO | Test items | Test condition |
|----|---|---|
| 1 | Low-Temperature Storage | T = -25°C, 500 h Test in white pattern |
| 2 | High-Temperature Storage | T=60°C, RH=35%, 500h Test in white pattern |
| 3 | High-Temperature Operation | T=50°C, RH=30%, 500h |
| 4 | Low-Temperature Operation | 0°C, 500h |
| 5 | High-Temperature, High-Humidity Operation | T=40°C, RH=90%, 500h |
| 6 | High-Temperature, High-Humidity Storage | T=60°C, RH=80%, 500h Test in white pattern |
| 7 | Temperature Cycle | 1 cycle:[-25°C 30min]→[+60 °C 30 min] : 100 cycles Test in white pattern |

Note: 1. Stay white pattern for storage and non-operation test.

2. Operation is black→white→red→yellow pattern, the interval is 150s.

3. Put in 20°C--25°C for 1hour after test finished, The function ,appearance and display performance is OK.



12. Quality Assurance

12.1 Environment

Temperature: 23±2°C

Humidity: 55±10%RH

12.2 Illuminance

Brightness: 1200~1500LUX; distance: 20-30CM; Angle: Relate 45° surround.

12.3 Inspect method

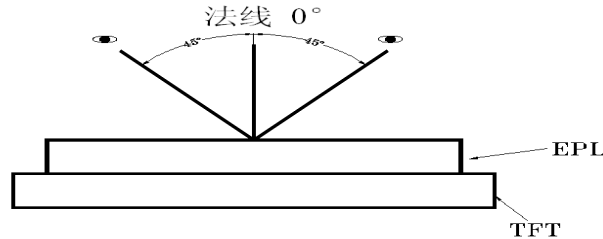

12.4 Display are

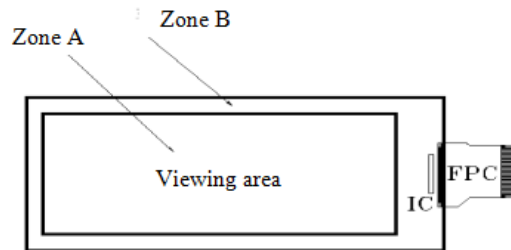

12.5 Ghosting test method

Three-color ghosting is measured with following transition from horizontal 4 scale pattern to vertical 4 scale pattern. The listed optical characteristics are only guaranteed under the controller & waveform provided by OKRA.



1) Measurement Instruments: X-rite i1Pro

2) Ghosting formula:

W ghosting: $\Delta E = \text{Max} (\Delta E_{ab}(Y-W, R-W), \Delta E_{ab}(Y-W, W-W), \Delta E_{ab}(Y-W, B-W), \Delta E_{ab}(R-W, W-W), \Delta E_{ab}(R-W, B-W), \Delta E_{ab}(W-W, B-W))$

K ghosting: $\Delta E = \text{Max} (\Delta E_{ab}(Y-B, R-B), \Delta E_{ab}(Y-B, W-B), \Delta E_{ab}(Y-B, B-B), \Delta E_{ab}(R-B, W-B), \Delta E_{ab}(R-B, B-B), \Delta E_{ab}(W-B, B-B))$

R ghosting: $\Delta E = \text{Max} (\Delta E_{ab}(Y-R, R-R), \Delta E_{ab}(Y-R, W-R), \Delta E_{ab}(Y-R, B-R), \Delta E_{ab}(R-R, W-R), \Delta E_{ab}(R-R, B-R), \Delta E_{ab}(W-R, B-R))$

Y ghosting: $\Delta E = \text{Max} (\Delta E_{ab}(Y-Y, R-Y), \Delta E_{ab}(Y-Y, W-Y), \Delta E_{ab}(Y-Y, B-Y), \Delta E_{ab}(R-Y, W-Y), \Delta E_{ab}(R-Y, B-Y), \Delta E_{ab}(W-Y, B-Y))$



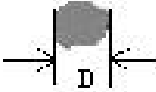
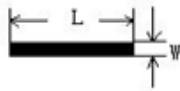

12.6 Inspection standard

12.6.1 Electric inspection standard



| NO. | Item | Standard | Defect level | Method | Scope |
|-----|--|---|--------------|----------------------------|------------------|
| 1 | Display | Clear display Display complete Display uniform | MA | | |
| 2 | Black/White spots |  $D \leq 0.25\text{mm}$, Allowed $0.25\text{mm} < D \leq 0.4\text{mm}$. $N \leq 4$ allowable $D > 0.4\text{mm}$ is not allowed | MI | Visual inspection | Zone A |
| 3 | Black/White lines (No switch) |  $L \leq 0.4\text{mm}, W \leq 0.1\text{mm}$ negligible $0.4\text{mm} < L \leq 1.0\text{mm}$ $0.1\text{mm} < W \leq 0.4\text{mm}$ $N \leq 4$ allowable $L > 1.0\text{mm}, W > 0.4\text{mm}$ is not allowed | | Visual/ Inspection card | |
| 4 | Ghost image | Allowed in switching process | MI | Visual inspection | |
| 5 | Flash dot / Multilateral | Flash points are allowed when switching screens Multilateral colors outside the frame are allowed for fixed screen time | MI | Visual/ Inspection card | Zone A Zone B |
| 6 | Segmented display | Selection segments are all displayed, and other segments are not displayed after the selection segment. | MA | Visual inspection | Zone A |
| 7 | Short circuit/ Circuit break/ Abnormal Display | Not Allow | | | |

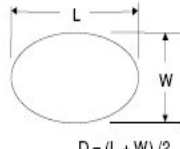
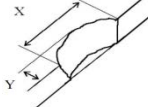
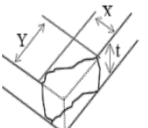
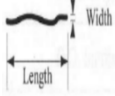

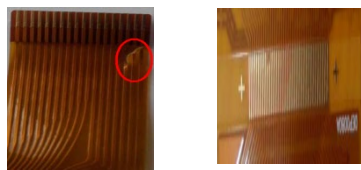
12.6.2 Appearance inspection standard

| NO. | Item | Standard | Defect level | Method | Scope |
|-----|---|--|--------------|------------------------|--------------------|
| 1 | B/W spots /Bubble/ Foreign bodies/ Dents |  <p>$D = (L + W) / 2$</p> <p>$D \leq 0.25\text{mm}$ negligible $0.25\text{mm} < D \leq 0.4\text{mm}$ $N \leq 4$ allowable $D > 0.4\text{mm}$ is not allowed</p> | MI | Visual inspection | Zone A |
| 2 | Glass crack | Not Allow | MA | Visual / Microscope | Zone A Zone B |
| 3 | \Dirty | Allowed if can be removed | MI | | Zone A Zone B |
| 4 | Chips/Scratch/ Edge crown |  <p>$X \leq 3\text{mm}, Y \leq 0.5\text{mm}$ And without affecting the electrode is permissible</p>  <p>$2\text{mm} \leq X$ or $2\text{mm} \leq Y$ $t =$ not counted. and without affecting the electrode, permissible</p>  <p>$W \leq 0.1\text{mm}, L \leq 5\text{mm}$, without affecting the electrode, $n \leq 2$</p> | MI | Visual / Microscope | Zone A Zone B |
| 5 | TFT Cracks |  <p>Not Allow</p> | MA | Visual / Microscope | Zone A Zone B |
| 6 | Dirty/ foreign body | Allowed if can be removed/ allow | MI | Visual / Microscope | Zone A / Zone B |
| 7 | FPC broken/ FPC oxidation / scratch |  <p>Not Allow</p> | MA | Visual / Microscope | Zone B |



| | | | | | |
|----|--|--|----|---------------------|------------------|
| 8 | B/W Line |  <p> $L \leq 0.4\text{mm}, W \leq 0.1\text{mm}$ negligible $0.4\text{mm} < L \leq 1.0\text{mm}$ $0.1\text{mm} < W \leq 0.4\text{mm}$ $N \leq 4$ allowable $L > 1.0\text{mm}, W > 0.4\text{mm}$ is not allowed </p> | MI | Visual / Ruler | Zone B |
| 9 | TFT edge bulge /TFT chromatic aberration | <p>TFT edge bulge: $X \leq 3\text{mm}, Y \leq 0.3\text{mm}$ Allowed TFT chromatic aberration :Allowed</p> | MI | Visual / Microscope | Zone A Zone B |
| 10 | Electrostatic point | <p> $D \leq 0.2\text{mm}$, allow $0.2\text{mm} < D \leq 0.35\text{mm}$, $n \leq 4$ allow $D > 0.35\text{mm}$ is not allowed ($n \leq 5$ items are allowed within 5 mm in diameter) </p> | MI | Visual / Microscope | Zone A |
| 11 | PCB damaged/ Poor welding/ Curl | <p>PCB (Circuit area) damaged Not Allow PCB Poor welding Not Allow PCB Curl $\leq 1\%$</p> | MI | Visual / Ruler | Zone B |
| 12 | Edge glue height/ Edge glue bubble | <p>Edge Adhesives $H \leq PS$ surface (Including protect film) Edge adhesives seep in $\leq 1/2$ Margin width Length excluding Edge adhesives bubble: bubble Width $\leq 1/2$ Margin width; Length $\leq 5.0\text{mm}$. $n \leq 5$</p> | MI | | |
| 13 | Protect film | <p>Surface scratch but not effect protect function, Allow</p> | MI | | |
| 14 | Silicon glue | <p>Thickness $\leq PS$ surface (With protect film): Full cover the IC; Shape: The width on the FPC $\leq 0.5\text{mm}$ (Front) The width on the FPC $\leq 1.0\text{mm}$ (Back) smooth surface, No obvious raised.</p> | MI | Visual Inspection | |
| 15 | Warp degree (TFT substrate) |  <p>$t \leq 1.0\text{mm}$</p> | MI | Ruler | |
| 16 | Color difference in COM area (Silver point area) | Allowed | | Visual Inspection | |

13.Packaging

TBD



14. Handling, Safety, and Environment Requirements

Warning

The display glass may break when it is dropped or bumped on a hard surface. Handle with care. Should the display break, do not touch the electrophoretic material. In case of contact with electrophoretic material, wash with water and soap.

Caution

The display module should not be exposed to harmful gases, such as acid and alkali gases, which corrode electronic components. Disassembling the display module.

Disassembling the display module can cause permanent damage and invalidates the warranty agreements.

Observe general precautions that are common to handling delicate electronic components. The glass can break and front surfaces can easily be damaged. Moreover the display is sensitive to static electricity and other rough environmental conditions.

| Data sheet status | |
|---|--|
| Product specification | This data sheet contains final product specifications. |
| Limiting values | |
| Limiting values given are in accordance with the Absolute Maximum Rating System (IEC 134). Stress above one or more of the limiting values may cause permanent damage to the device. These are stress ratings only and operation of the device at these or at any other conditions above those given in the Characteristics sections of the specification is not implied. Exposure to limiting values for extended periods may affect device reliability. | |
| Application information | |
| Where application information is given, it is advisory and does not form part of the specification. | |
| Product Environmental certification | |
| ROHS | |
| REMARK | |
| All The specifications listed in this document are guaranteed for module only. Post-assembled operation or component(s) may impact module performance or cause unexpected effect or damage and therefore listed specifications is not warranted after any Post-assembled operation. | |
| Transport environment | |
| When the humidity of transportation environment is between 45%RH~70%RH, the product can be stored for 30 days, and the product can be stored for 10 days if it is lower or higher than this range | |