



Specification for 0.97 inch EPD

Model NO. : OKRA0097BNS800F1

OKRA's Confirmation:

Prepared by	Checked by	Approved by

Customer approval:

Customer	Approved by	Date



Revision History

Version	Content	Date	Producer
2.0	New release	2023/02/16	



CONTENTS

1. Over View	3
2. Features	4
3. Mechanical and Optical Specification	5
4. Mechanical Drawing of EPD Module	6
5. Input/output Pin Assignment	7
6. Electrical Characteristics	8
6.1 Absolute Maximum Rating	8
6.2 Panel DC Characteristics	9
6.3 Panel AC Characteristics	10
6.3.1 MCU Interface Selection	10
6.3.2 MCU Serial Interface (4-wire SPI)	10
6.3.3 MCU Serial Interface (3-wire SPI)	11
6.3.4 Interface Timing	11
7.Command Table	13
8. Block Diagram	47
9. Typical Application Circuit with SPI Interface	48
10 Typical Operating Sequence	49
10.1 LUT from OTP Operation Flow	49
10.2 OTP Operation Reference Program Code	50
11. Reliability Test	51
12.Quality Assurance	52
12.1 Environment	52
12.2 Illuminance	52
12.3 Inspect method	52
12.4 Display are	52
12.5 Ghosting test method	52
12.6 Inspection standard	53
12.6.1 Electric inspection standard	53
12.6.2 Appearance inspection standard	54
13.Packaging	56
14.Handling, Safety, and Environment Requirements	57



1. Over View

OKRA0266RYF661F34 is an Active Matrix EPD all-in-one driver with timing controller for ESL. The sources have 2-bit outputs per pixel to support white/black/red/yellow. The 2.66 inch active area contains 296×152 pixels. The module is a TFT-array driving electrophoresis display, with integrated circuits including gate driver, source driver, MCU interface, timing controller, oscillator, DC-DC, SRAM, LUT, VCOM. Module can be used in portable electronic devices, such as Electronic Shelf Label (ESL) System.

2. Features

- ◆ 296×152 pixels display
- ◆ High contrast High reflectance
- ◆ Ultra wide viewing angle Ultra low power consumption
- ◆ Pure reflective mode
- ◆ Bi-stable display
- ◆ Commercial temperature range
- ◆ Landscape portrait modes
- ◆ Hard-coat antiglare display surface
- ◆ Ultra Low current deep sleep mode
- ◆ On chip display RAM
- ◆ Waveform can stored in On-chip OTP or written by MCU
- ◆ Serial peripheral interface available
- ◆ On-chip oscillator
- ◆ On-chip booster and regulator control for generating VCOM, Gate and Source driving voltage
- ◆ I²C signal master interface to read external temperature sensor
- ◆ Built-in temperature sensor



3. Mechanical and Optical Specification

Parameter	Specifications	Unit	Remark
Screen Size	2.66	Inch	
Display Resolution	296(V) × 152(H)	Pixel	DPI:125
Active Area	30.70 × 60.09	mm	
Pixel Pitch	0.202 × 0.203	mm	
Pixel Configuration	Rectangle		
Outline Dimension	36.30(H) × 71.82 (V) × 1.0(D)	mm	
Weight	4.94 ± 0.5	g	

Temperature Range(°C)		0-9	10-19	20-29	30-40	Units
White State	TYP L*	62	62	61	60	
	MIN L*	60	60	59.5	58	
	b*	≤2.5	≤2.5	≤2.5	≤2.5	
Black State	TYP L*	9	9	9	9	
	MAX L*	12	12	12	12	
	a*	≤9	≤9	≤8	≤10	
Red State	MIN L*	23	23	24	23	
	TYP a*	36	38	40	40	
	MIN a*	34	34	38	38	
	MAX b*	34	34	34	34	
Yellow State	MIN L*	50	50	54	54	
	TYP b*	55	63	66	66	
	MIN b*	49.5	53	60	60	
	MAX a*	18	18	18	18	
Ghosting		≤2	≤2	≤2	≤2	delta E

Notes: 3-1. Luminance meter: Eye-One Pro Spectrophotometer.



4. Mechanical Drawing of EPD Module

Confirmation:	DATE 2023-01-30	REV. A	MODIFICATION FIRST ISSUE
---------------	--------------------	-----------	-----------------------------

FRONT VIEW

SIDE VIEW

BACK VIEW

NOTE

- 1 DISPLAY MODULE 2.66" ARRAY FOR EPD
- 2 DRIVER IC: JD79661
- 3 RESOLUTION: 296gateX152source
- 4 PIXEL SIZE: 0.202mmX 0.203 mm

TOLERANCES UNMARKED	TITLE:	PROJECT:	REV.:	DATE:	CUST. P/N:
ANGLES ±5°	EPD	0266_F001F34	A	23.01.30	
.X=±0.4mm	DWN:	CHK:	UNIT:	3RD ANGLE:	PAGE:
.XX=±0.20mm	Z FU	NN ZHAO	mm		1/1
.XXX=±0.20mm		SY ZHAO			



5. Input/output Pin Assignment

No.	Name	I/O	Description	Remark
1	NC		Do not connect with other NC pins	Keep Open
2	GDR	O	N-Channel MOSFET Gate Drive Control	
3	RESE	I	Current Sense Input for the Control Loop	
4	NC	NC	Do not connect with other NC pins	Keep Open
5	VSH2	C	Positive Source driving voltage(Red)	
6	NC		Do not connect with other NC pins	Keep Open
7	NC		Do not connect with other NC pins	Keep Open
8	BS1	I	Bus Interface selection pin	Note 5-5
9	BUSY	O	Busy state output pin	Note 5-4
10	RES#	I	Reset signal input. Active Low.	Note 5-3
11	D/C#	I	Data /Command control pin	Note 5-2
12	CS#	I	Chip select input pin	Note 5-1
13	SCL	I	Serial Clock pin (SPI)	
14	SDA	I/O	Serial Data pin (SPI)	
15	VDDIO	P	Power Supply for interface logic pins It should be connected with VCI	
16	VCI	P	Power Supply for the chip	
17	VSS	P	Ground	
18	VDD	C	Core logic power pin VDD can be regulated internally from VCI. A capacitor should be connected between VDD and VSS	
19	VPP	P	FOR TEST	Keep Open
20	VSH1	C	Positive Source driving voltage	
21	VGH	C	Power Supply pin for Positive Gate driving voltage and VSH1	
22	VSL	C	Negative Source driving voltage	
23	VGL	C	Power Supply pin for Negative Gate driving voltage VCOM and VSL	
24	VCOM	C	VCOM driving voltage	

I = Input Pin, O =Output Pin, I/O = Bi-directional Pin (Input/output), P = Power Pin, C = Capacitor Pin



Note 5-1: This pin (CS#) is the chip select input connecting to the MCU. The chip is enabled for MCU communication only when CS# is pulled LOW.

Note 5-2: This pin is (D/C#) Data/Command control pin connecting to the MCU in 4-wire SPI mode. When the pin is pulled HIGH, the data at SDA will be interpreted as data. When the pin is pulled LOW, the data at SDA will be interpreted as command.

Note 5-3: This pin (RES#) is reset signal input. The Reset is active low.

Note 5-4: This pin is Busy state output pin. When Busy is Low, the operation of chip should not be interrupted, command should not be sent. The chip would put Busy pin Low when -Outputting display waveform -Communicating with digital temperature sensor

Note 5-5: Bus interface selection pin

BS1 State	MCU Interface
L	4-lines serial peripheral interface(SPI) - 8 bits SPI
H	3- lines serial peripheral interface(SPI) - 9 bits SPI

6. Electrical Characteristics

6.1 Absolute Maximum Rating

Parameter	Symbol	Rating	Unit
Logic supply voltage	VCI	-0.3 to +6.0	V
Logic Input voltage	VIN	-0.3 to VCI +0.3	V
Operating Temp range	TOPR	0 to +40	°C.
Storage Temp range	TSTG	-25 to+70	°C.
Optimal Storage Temp	TSTGo	23±2	°C.
Optimal StorageHumidity	HSTGo	55±10	%RH

Note:

1. Maximum ratings are those values beyond which damages to the device may occur. Functional operation should be restricted to the limits in the Panel DC Characteristics tables.

2. The storage time is within 10 days for -25°C ~ 70°C.

The display screen should be kept white and face up.



6.2 Panel DC Characteristics

The following specifications apply for: VSS=0V, VCI=3.0V, TOPR =23°C.

Parameter	Symbol	Condition	Applicable pin	Min.	Typ.	Max.	Unit
Single ground	VSS	-		-	0	-	V
Logic supply voltage	VCI	-	VCI	2.3	3.0	3.6	V
Core logic voltage	VDD		VDD	2.3	3.0	3.6	V
High level input voltage	V _{IH}	-	-	0.7 VCI	-	VCI	V
Low level input voltage	V _{IL}	-	-	0	-	0.3 VCI	V
High level output voltage	V _{OH}	I _{OH} = 400Ma	-	VCI -0.4	-	-	V
Low level output voltage	V _{OL}	I _{OL} = -400Ma	-	-	-	GND +0.4	V
Typical power	P _{TYP}	VCI =3.0V	-	-	12	-	mW
Deep sleep mode	P _{STPY}	VCI =3.0V	-	-	0.0012	-	mW
Typical operating current	I _{opr_VCI}	VCI =3.0V	-	-	3.5	-	mA
Image update time	-	23 °C	-	-	18	-	sec
Typical peak current	I _{opr_VCI}	2.3~3.6V	-	-	30	40	mA
Deep sleep mode current	I _{dslp_VCI}	DC/DC off No clock No input load Ram data not retain	-	-	0.4	1	uA

Notes: 1. The typical power is measured with following transition from horizontal 4 scale pattern to vertical 4 scale pattern.

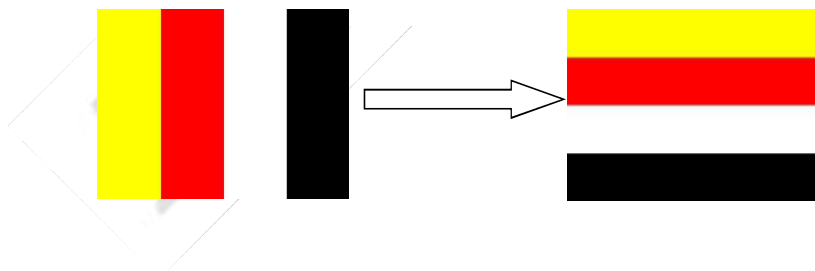

2. The deep sleep power is the consumed power when the panel controller is in deep sleep mode.

3. The listed electrical/optical characteristics are only guaranteed under the controller & waveform provided by

4. Electrical measurement: Tektronix oscilloscope - MDO3024,

Tektronix current probe - TCP0030A.



6.3 Panel AC Characteristics

6.3.1 MCU Interface Selection

The pin assignment at different interface mode is summarized in Table 6-3-1. Different MCU mode can be set by hardware selection on BS1 pins. The display panel only supports 4-wire SPI or 3-wire SPI interface mode.

Pin Name	Data/Command Interface		Control Signal		
Bus interface	SDA	SCL	CS#	D/C#	RES#
BS1=L 4-wire SPI	SDA	SCL	CS#	D/C#	RES#
BS1=H 3-wire SPI	SDA	SCL	CS#	L	RES#

Table 6-3-1: MCU interface assignment under different bus interface mode

6.3.2 MCU Serial Interface (4-wire SPI)

The serial interface consists of serial clock SCL, serial data SDA, D/C#, CS#. This interface supports Write mode and Read mode.

Function	CS#	D/C#	SCL
Write command	L	L	↑
Write data	L	H	↑

Table 6-3-2: Control pins of 4-wire Serial Peripheral interface

Note: ↑ stands for rising edge of signal

Figure 6-3-1: 4-wire SPI mode

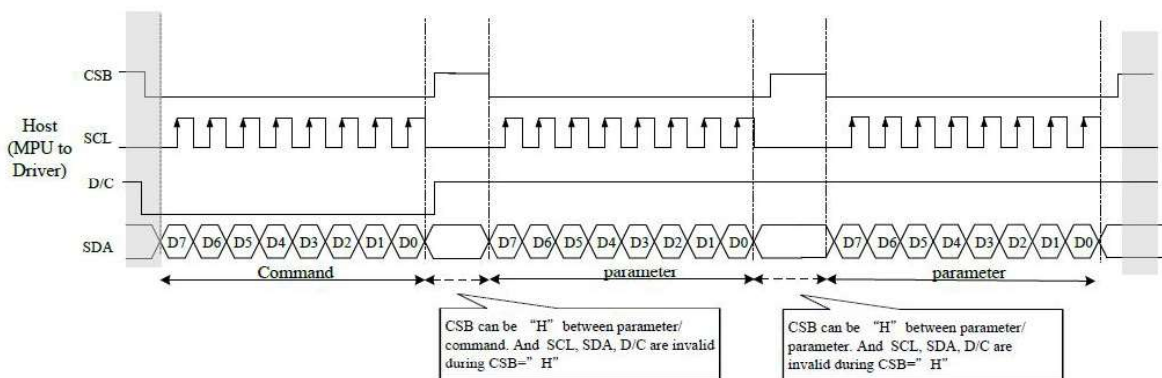



6.3.3 MCU Serial Interface (3-wire SPI)

Function	CS#	D/C#	SCL
Write command	L	Tie	↑
Write data	L	Tie	↑

Table 6-3-3: Control pins of 4-wire Serial Peripheral interface

Note: ↑ stands for rising edge of signal

Figure 6-3-2: 3-wire SPI mode

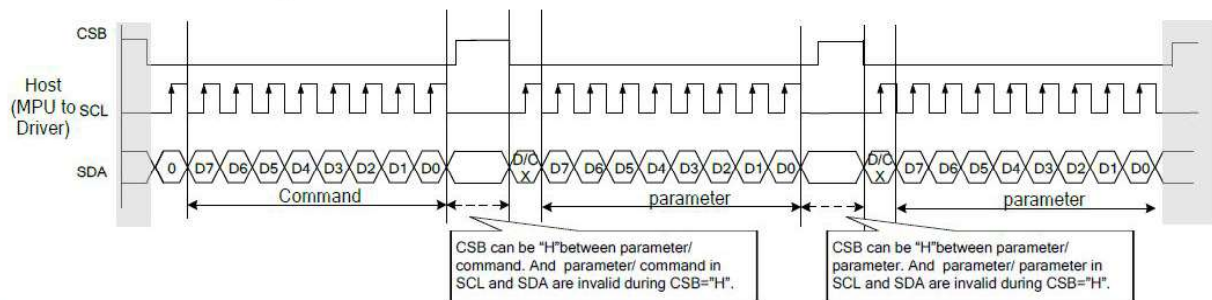

6.3.4 Interface Timing

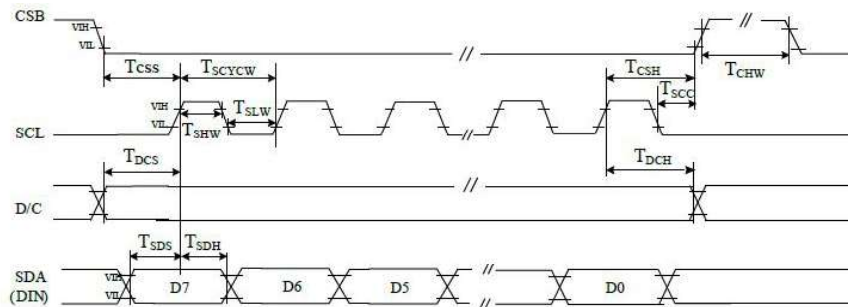

4 pin serial interface characteristics(write mode)

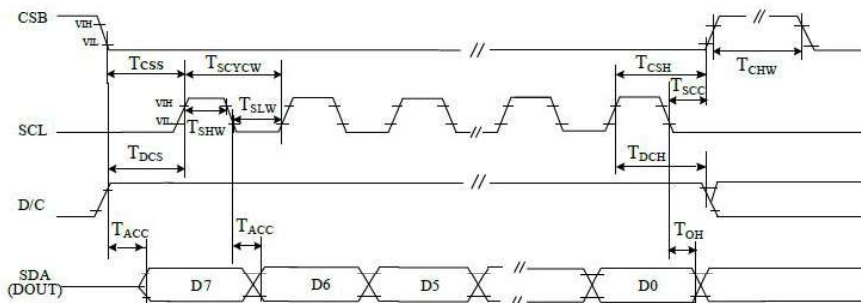

**Serial Interface Timing Characteristics**

Parameter	Symbol	Min.	Typ.	Max.	Unit	Condition
SERIAL COMMUNICATION						
CSB	T _{css}	60			ns	Chip select setup time
	T _{csh}	65			ns	Chip select hold time
	T _{scc}	20			ns	Chip select CSB setup time
	T _{chw}	40			ns	Chip select setup time
SCL	T _{scycw}	100			ns	Serial clock cycle (Write)
	T _{shw}	35			ns	SCL "H" pulse width (Write)
	T _{slw}	35			ns	SCL "L" pulse width (Write)
	T _{scycr}	150			ns	Serial clock cycle (Read)
	T _{shr}	60			ns	SCL "H" pulse width (Read)
	T _{slr}	60			ns	SCL "L" pulse width (Read)
SDA (DIN) (DOUT)	T _{sdS}	30			ns	Data setup time
	T _{sdH}	30			ns	Data hold time
	T _{acc}			10	ns	Access time
	T _{oh}	15			ns	Output disable time
D/C	T _{dcs}	20			ns	DC setup time
	T _{dch}	20			ns	DC hold time



7.Command Table

R/W: 0:Write Cycle 1:Read Cycle D/CX:0:Command/1:Data D7~D0:-Don't Care

1)R00H (PSR): Panel setting Register

R00H	Bit										
Inst/Para	R/W	D/CX	D7	D6	D5	D4	D3	D2	D1	D0	Code
PSR	W	0	0	0	0	0	0	0	0	0	00H
1 st Parameter	W	1	RES[1]	RES[0]	PST_MODE	-	UD	SHL	SHD_N	RST_N	0Fh
2 nd Parameter	W	1	LUT_EN	-	FOPT	VCMZ	TS_AUTO	TIEG	NORG	VC_LUTZ	09h

NOTE: "-" Don't care, can be set to VDD or GND level

Description	-The command defines as :		
	1 st parameter		
	Bit	Name	Description
	0	RST_N	RST_N function 1: no effect. (default) 0: Booster OFF, Register data are set to their default values, and Source/Boder/Vcom: floating
	1	SHD_N	SHD_N function 0 : Booster OFF, register data are kept, and Source/Boder/Vcom are kept 0V or floating. 1 : Booster on. (default)
	2	SHL	SHL function 0: Shift left; First data=Sn→Sn-1 →...→S2→Last data=S1. 1: Shift right; First data=S1→S2 →...→Sn-1→Last data=Sn. (default)
	3	UD	UD function 0: Scan down; First line=Gn→Gn-1 →...→G2→Last line=G1. 1: Scan up; First line=G1→G2 →...→Gn-1→Last line=Gn. (default)
	5	PST_MODE	Power switch operation mode 0: Power switching time in the period of frame scanning. (default) 1: Power switching time in the external period before frame scanning.
7-6	RES[1,0]	Resolution setting 00: Display resolution is 176x296 (default) 01: Display resolution is 128x296 10: Display resolution is 128x250 11: Display resolution is 112x204	



2 nd parameter		
Bit	Name	Description
0	VC_LUTZ	VCOM status function 0 : No effect 1 : After refreshing display,the output of VCOM is set to floating automatically (default)
1	NORG	VCOM status function 0 : No effect (default) 1 : After refreshing display, VCOM is tied to GND before power off
2	TIEG	VGN power off status function 0 : No effect (default) 1 : Power off, VGN will be tied to GND
3	TS_AUTO	Temperature sensing will be activated automatically one time 0 : Before enabling booster, Temperature Sensor will be activated automatically one time. 1 : When RST_N low to high, Temperature Sensor will be activated automatically one time. (default)
4	VCMZ	VCOM status function 0 : No effect (default) 1 : VCOM is always floating
5	FOPT	FOPT function 0: Scan 1 frame after waveform finished(default) 1: No scan after waveform finished and switch the source channel output to Hiz.
7	LUT_EN	LUT selection setting 0 : Using LUT from MTP(default) 1 : Using LUT from register
<p>Priority of VCOM setting: VCMZ > NORG > FOPT > VC_LUTZ</p> <p>FOPT setting is part of refreshing display. FOPT: Power off floating.</p> <p>Notes:</p> <ol style="list-style-type: none"> 1. Non-select gate line keep at VGN for DSP/DRF and AMV 2. Dummy source line follow LUTC for DSP/DRF 3. When SHD_N become low, DCDC will turn off. Register and SRAM data will keep until VDD turn off. SD output and VCOM will base on previous condition. It may have two condition: 0V or floating. 4. When RST_N become low, driver will reset. All register will reset to default value. All of the driver's functions will disable. Source/Gate/Border/VCOM will be released to floating 		
Restriction		



2) R01H (PWR): Power setting Register

R01H	Bit										
Inst/Para	R/W	D/CX	D7	D6	D5	D4	D3	D2	D1	D0	Code
PWR	W	0	0	0	0	0	0	0	0	1	01h
1 st Parameter	W	1	-	-	-	-	V_MODE	VSC_EN	VDS_EN	VDG_EN	07h
2 nd Parameter	W	1	-	-	-	-	-	-	VGPN [1]	VGPN [0]	00h
3 rd Parameter	W	1	-	VSPL_0 [6:0]							00h
4 th Parameter	W	1	-	VSP_1 [6:0]							00h
5 th Parameter	W	1	-	VSN_1 [6:0]							00h
6 th Parameter	W	1	-	VSPL_1 [6:0]							00h

NOTE: "-" Don't care, can be set to VDD or GND level

Description	-The command defines as :	
	1 st Parameter:	
	Bit	Name
	0	VDG_EN
	1	VDS_EN
	2	VSC_EN
3	V_MODE	
2nd Parameter:		
Bit	Name	
1-0	VGPN	



3rd & 4th & 6th Parameter: Internal VSP_1/VSP_0/ VSPL_1 power selection

Bit	Name	Description								
6-0	VSP_1 & VSP_0 & VSPL_1	Internal VSP & VSPL power selection.								
		bit(6:0)	Voltage(V)	bit(6:0)	Voltage(V)	bit(6:0)	Voltage(V)			
		0000000	00h	3	0101001	29h	7.1	1010010	52h	11.2
		0000001	01h	3.1	0101010	2Ah	7.2	1010011	53h	11.3
		0000010	02h	3.2	0101011	2Bh	7.3	1010100	54h	11.4
		0000011	03h	3.3	0101100	2Ch	7.4	1010101	55h	11.5
		0000100	04h	3.4	0101101	2Dh	7.5	1010110	56h	11.6
		0000101	05h	3.5	0101110	2Eh	7.6	1010111	57h	11.7
		0000110	06h	3.6	0101111	2Fh	7.7	1011000	58h	11.8
		0000111	07h	3.7	0110000	30h	7.8	1011001	59h	11.9
		0001000	08h	3.8	0110001	31h	7.9	1011010	5Ah	12
		0001001	09h	3.9	0110010	32h	8	1011011	5Bh	12.1
		0001010	0Ah	4	0110011	33h	8.1	1011100	5Ch	12.2
		0001011	0Bh	4.1	0110100	34h	8.2	1011101	5Dh	12.3
		0001100	0Ch	4.2	0110101	35h	8.3	1011110	5Eh	12.4
		0001101	0Dh	4.3	0110110	36h	8.4	1011111	5Fh	12.5
		0001110	0Eh	4.4	0110111	37h	8.5	1100000	60h	12.6
		0001111	0Fh	4.5	0111000	38h	8.6	1100001	61h	12.7
		0010000	10h	4.6	0111001	39h	8.7	1100010	62h	12.8
		0010001	11h	4.7	0111010	3Ah	8.8	1100011	63h	12.9
		0010010	12h	4.8	0111011	3Bh	8.9	1100100	64h	13
		0010011	13h	4.9	0111100	3Ch	9	1100101	65h	13.1
		0010100	14h	5	0111101	3Dh	9.1	1100110	66h	13.2
		0010101	15h	5.1	0111110	3Eh	9.2	1100111	67h	13.3
		0010110	16h	5.2	0111111	3Fh	9.3	1101000	68h	13.4
		0010111	17h	5.3	1000000	40h	9.4	1101001	69h	13.5
		0011000	18h	5.4	1000001	41h	9.5	1101010	6Ah	13.6
		0011001	19h	5.5	1000010	42h	9.6	1101011	6Bh	13.7
		0011010	1Ah	5.6	1000011	43h	9.7	1101100	6Ch	13.8
		0011011	1Bh	5.7	1000100	44h	9.8	1101101	6Dh	13.9
0011100	1Ch	5.8	1000101	45h	9.9	1101110	6Eh	14		
0011101	1Dh	5.9	1000110	46h	10	1101111	6Fh	14.1		
0011110	1Eh	6	1000111	47h	10.1	1110000	70h	14.2		
0011111	1Fh	6.1	1001000	48h	10.2	1110001	71h	14.3		
0100000	20h	6.2	1001001	49h	10.3	1110010	72h	14.4		
0100001	21h	6.3	1001010	4Ah	10.4	1110011	73h	14.5		
0100010	22h	6.4	1001011	4Bh	10.5	1110100	74h	14.6		
0100011	23h	6.5	1001100	4Ch	10.6	1110101	75h	14.7		
0100100	24h	6.6	1001101	4Dh	10.7	1110110	76h	14.8		
0100101	25h	6.7	1001110	4Eh	10.8	1110111	77h	14.9		
0100110	26h	6.8	1001111	4Fh	10.9	1111000	78h	15		
0100111	27h	6.9	1010000	50h	11	other	15			
0101000	28h	7	1010001	51h	11.1					



5th Parameter: Internal VSN_1 power selection

Bit	Name	Description					
Internal VSN power selection:							
		bit [6:0]	Voltage(V)	bit [6:0]	Voltage(V)	bit [6:0]	Voltage(V)
		0000000	00h -3	0101001	29h -7.1	1010010	52h -11.2
		0000001	01h -3.1	0101010	2Ah -7.2	1010011	53h -11.3
		0000010	02h -3.2	0101011	2Bh -7.3	1010100	54h -11.4
		0000011	03h -3.3	0101100	2Ch -7.4	1010101	55h -11.5
		0000100	04h -3.4	0101101	2Dh -7.5	1010110	56h -11.6
		0000101	05h -3.5	0101110	2Eh -7.6	1010111	57h -11.7
		0000110	06h -3.6	0101111	2Fh -7.7	1011000	58h -11.8
		0000111	07h -3.7	0110000	30h -7.8	1011001	59h -11.9
		0001000	08h -3.8	0110001	31h -7.9	1011010	5Ah -12
		0001001	09h -3.9	0110010	32h -8	1011011	5Bh -12.1
		0001010	0Ah -4	0110011	33h -8.1	1011100	5Ch -12.2
		0001011	0Bh -4.1	0110100	34h -8.2	1011101	5Dh -12.3
		0001100	0Ch -4.2	0110101	35h -8.3	1011110	5Eh -12.4
		0001101	0Dh -4.3	0110110	36h -8.4	1011111	5Fh -12.5
		0001110	0Eh -4.4	0110111	37h -8.5	1100000	60h -12.6
		0001111	0Fh -4.5	0111000	38h -8.6	1100001	61h -12.7
		0010000	10h -4.6	0111001	39h -8.7	1100010	62h -12.8
		0010001	11h -4.7	0111010	3Ah -8.8	1100011	63h -12.9
		0010010	12h -4.8	0111011	3Bh -8.9	1100100	64h -13
		0010011	13h -4.9	0111100	3Ch -9	1100101	65h -13.1
		0010100	14h -5	0111101	3Dh -9.1	1100110	66h -13.2
		0010101	15h -5.1	0111110	3Eh -9.2	1100111	67h -13.3
		0010110	16h -5.2	0111111	3Fh -9.3	1101000	68h -13.4
		0010111	17h -5.3	1000000	40h -9.4	1101001	69h -13.5
		0011000	18h -5.4	1000001	41h -9.5	1101010	6Ah -13.6
		0011001	19h -5.5	1000010	42h -9.6	1101011	6Bh -13.7
		0011010	1Ah -5.6	1000011	43h -9.7	1101100	6Ch -13.8
		0011011	1Bh -5.7	1000100	44h -9.8	1101101	6Dh -13.9
		0011100	1Ch -5.8	1000101	45h -9.9	1101110	6Eh -14
		0011101	1Dh -5.9	1000110	46h -10	1101111	6Fh -14.1
		0011110	1Eh -6	1000111	47h -10.1	1110000	70h -14.2
		0011111	1Fh -6.1	1001000	48h -10.2	1110001	71h -14.3
		0100000	20h -6.2	1001001	49h -10.3	1110010	72h -14.4
		0100001	21h -6.3	1001010	4Ah -10.4	1110011	73h -14.5
		0100010	22h -6.4	1001011	4Bh -10.5	1110100	74h -14.6
		0100011	23h -6.5	1001100	4Ch -10.6	1110101	75h -14.7
		0100100	24h -6.6	1001101	4Dh -10.7	1110110	76h -14.8
		0100101	25h -6.7	1001110	4Eh -10.8	1110111	77h -14.9
		0100110	26h -6.8	1001111	4Fh -10.9	1111000	78h -15
		0100111	27h -6.9	1010000	50h -11	other	-15
		0101000	28h -7	1010001	51h -7.1		

6-0 VSN_1



Notes:

- VSP_0/VSN_0 voltage output is ± 15 V fixed value.
- When switching Mode0 or Mode1, the voltage output is:
 Mode0: VSP_0(+15) / VSN_0 (-15) / VSPL_0 (+3--+15)
 Mode1: VSP_1(+3 - +15) / VSN_1(-3 - -15) / VSPL_1(+3 - +15)

	Mode0	Mode1
VSP	VSP_0(+15)	VSP_1(+3--+15)
VSN	VSN_0(-15)	VSN_1(-3--15)
VSPL	VSPL_0(+3--+15)	VSPL_1(+3--+15)

- If gate voltage is set to ± 15 v, ± 10 v, IC will auto correct source voltage as follows
 I. VGP- VSP_0 / VSPL_0 / VSP_1 / VSPL_1 ≥ 2 v
 II. VGN- VSN_0 / VSN_1 ≥ -2 v
 For example:

	symbol	Voltage setting	Real Voltage
Voltage	VGP	10v	+10v
	VGN	10v	-10v
	VSP_0	+15v	+8v
	VSN_0	-15v	-8v
	VSP_1	+5v	+5v
	VSN_1	-5v	-5v
	VSPL	+15v	+8v
	VCOMH	+15v+(-2v)	+8v+(-2v)
	VCOML	-15v+(-2v)	-8v+(-2v)
	VCOMDC	-2v	-2v

- Voltage setting limit: VSP_0 \geq VSPL_0 , VSP_1 \geq VSPL_1

Restriction



3)R02H (POF): Power OFF Command

R02H	Bit										
Inst/Para	R/W	D/CX	D7	D6	D5	D4	D3	D2	D1	D0	Code
POF	W	0	0	0	0	0	0	0	1	0	02H
1 st Parameter	W	0	-	-	-	-	-	-	-	EDSE	00

NOTE: "-" Don't care, can be set to VDD or GND level

Description	<p>-The command defines as :</p> <ul style="list-style-type: none"> ● After power off command, driver will power off base on power off sequence. ● After power off command, BUSY_N signal will drop from high to low. When finish the power off sequence, BUSY_N signal will rise from low to high. ● Power off command will turn off charge pump, T-con, source driver, gate driver, VCOM, temperature sensor, but register and SRAM data will keep until VDD off. ● SD output and VCOM will base on previous condition. It may have two conditions: 0v or floating. <p>1st parameter</p> <table border="1" style="width: 100%;"> <thead> <tr> <th>Bit</th> <th>Name</th> <th>Description</th> </tr> </thead> <tbody> <tr> <td>0</td> <td>EDSE</td> <td>EPD Discharge Trigger 0 : Disable EPD discharge (default) 1 : Enable EPD discharge</td> </tr> </tbody> </table>	Bit	Name	Description	0	EDSE	EPD Discharge Trigger 0 : Disable EPD discharge (default) 1 : Enable EPD discharge
Bit	Name	Description					
0	EDSE	EPD Discharge Trigger 0 : Disable EPD discharge (default) 1 : Enable EPD discharge					
Restriction	This command only active when BUSY_N = "1".						



4)R03H (PFS): Power off Sequence Setting Register

R03H	Bit										
Inst/Para	R/W	D/CX	D7	D6	D5	D4	D3	D2	D1	D0	Code
PFS	W	0	0	0	0	0	0	0	1	1	03H
1 st Parameter	W	1	-		T_VDPG_OFF [1:0]		-		T_VDS_OFF [1:0]		00h
2 nd Parameter	W	1	VGP_LEN[3:0]				VGP_EXT[3:0]				54h
3 rd Parameter	W	1	XON_DLY[3:0]				XON_LEN[3:0]				44h

NOTE: "-" Don't care, can be set to VDD or GND level

Description	-The command defines as :		
	1 st Parameter:		
	Bit	Name	Description
	1-0	T_VDS_OFF	Power off sequence of VSP /VSN 00: 20 ms (default) 01: 40 ms 10: 60 ms 11: 80 ms
	5-4	T_VDPG_OFF	Power off sequence of VGP and VGN 00: 20 ms (default) 01: 40 ms 10: 60 ms 11: 80 ms
	2 nd Parameter		
	Bit	Name	Description
	1-0	VGP_EXT	VGP extension time 0000: 0 ms 0001: 500 ms 0010: 1000 ms 0011: 1500 ms 0100: 2000 ms (default) 0101: 2500 ms 0110: 3000 ms 0111: 3500 ms 1000: 4000 ms 1001: 4500 ms 1010: 5000 ms 1011: 5500 ms 1100: 6000 ms 1101: 6500 ms
	7-4	VGP_LEN	When power off, the length of time VGP stay 10V 0000: 0 ms 0001: 500 ms 0010: 1000 ms 0011: 1500 ms 0100: 2000 ms 0101: 2500 ms (default) 0110: 3000 ms 0111: 3500 ms 1000: 4000 ms 1001: 4500 ms 1010: 5000 ms 1011: 5500 ms



		1100: 6000 ms 1101: 6500 ms
3-Parameter:		
Bit	Name	Description
3-0	XON_LEN	XON enable time 0000: 0 ms 0001: 500 ms 0010: 1000 ms 0011: 1500 ms 0100: 2000 ms (default) 0101: 2500 ms 0110: 3000 ms 0111: 3500 ms 1000: 4000 ms 1001: 4500 ms 1010: 5000 ms 1011: 5500 ms 1100: 6000 ms
7-4	XON_DLY	XON delay time 0000: 0 ms 0001: 500 ms 0010: 1000 ms 0011: 1500 ms 0100: 2000 ms (default) 0101: 2500 ms 0110: 3000 ms 0111: 3500 ms 1000: 4000 ms 1001: 4500 ms 1010: 5000 ms 1011: 5500 ms 1100: 6000 ms
Restriction		



5)(R04H) (PON):Power ON Command

R04H	Bit										
Inst/Para	R/W	D/CX	D7	D6	D5	D4	D3	D2	D1	D0	Code
PON	W	0	0	0	0	0	0	1	0	0	04H

NOTE: "-" Don't care, can be set to VDD or GND level

Description	<p>-The command defines as :</p> <ul style="list-style-type: none"> ● After power on command, driver will power on base on power on sequence. ● After power on command, BUSY_N signal will drop from high to low. When finishing the power on sequence(base on PWR command), BUSY_N signal will rise from low to high.
Restriction	This command only active when BUSY_N = "1".



6) R06H (BTST): Booster Soft Start Command

R06H	Bit										
Inst/Para	R/W	D/CX	D7	D6	D5	D4	D3	D2	D1	D0	Code
BTST	W	0	0	0	0	0	0	1	1	0	06H
1 st Parameter	W	1	-	-	-	-	PHB_SFT [1:0]		PHA_SFT [1:0]		00h
2 nd Parameter	W	1	-	-	PHA_ON [5:0]						02h
3 rd Parameter	W	1	-	-	PHA_OFF [5:0]						07h
4 th Parameter	W	1	-	-	PHB_ON [5:0]						02h
5 th Parameter	W	1	-	-	PHB_OFF [5:0]						07h
6 th Parameter	W	1	-	-	PHC_ON [5:0]						02h
7 th Parameter	W	1	-	-	PHC_OFF [5:0]						07h

Description	-The command define as follows: 1 st Parameter:						
	Bit	Name	Description				
	1-0	PHA_SFT	Soft start period of phase A: 00: 10mS (default) 01: 20mS 10: 30mS 11: 40mS				
	3-2	PHB_SFT	Soft start period of phase B: 00: 10mS (default) 01: 20mS 10: 30mS 11: 40mS				
		Bit[5:0]	Description	Bit[5:0]	Description	Bit[5:0]	Description
		000000	strength1	010110	strength23	101100	strength45
		000001	strength2	010111	strength24	101101	strength46
		000010	strength3	011000	strength25	101110	strength47
		000011	strength4	011001	strength26	101111	strength48
		000100	strength5	011010	strength27	110000	strength49
		000101	strength6	011011	strength28	110001	strength50
		000110	strength7	011100	strength29	110010	strength51
		000111	strength8	011101	strength30	110011	strength52
		001000	strength9	011110	strength31	110100	strength53
		001001	strength10	011111	strength32	110101	strength54
		001010	strength11	100000	strength33	110110	strength55
		001011	strength12	100001	strength34	110111	strength56
		001100	strength13	100010	strength35	111000	strength57
		001101	strength14	100011	strength36	111001	strength58
		001110	strength15	100100	strength37	111010	strength59
		001111	strength16	100101	strength38	111011	strength60
		010000	strength17	100110	strength39	111100	strength61
		010001	strength18	100111	strength40	111101	strength62
		010010	strength19	101000	strength41	111110	strength63
		010011	strength20	101001	strength42	111111	strength64
		010100	strength21	101010	strength43		
		010101	strength22	101011	strength44		



Description	Bit[5:0]		Description		Bit[5:0]		Description	
	Minimum OFF time setting of PHA_OFF & PHB_OFF & PHC_OFF	000000	Period1	010110	Period23	101100	Period45	
000001		Period2	010111	Period24	101101	Period46		
000010		Period3	011000	Period25	101110	Period47		
000011		Period4	011001	Period26	101111	Period48		
000100		Period5	011010	Period27	110000	Period49		
000101		Period6	011011	Period28	110001	Period50		
000110		Period7	011100	Period29	110010	Period51		
000111		Period8	011101	Period30	110011	Period52		
001000		Period9	011110	Period31	110100	Period53		
001001		Period10	011111	Period32	110101	Period54		
001010		Period11	100000	Period33	110110	Period55		
001011		Period12	100001	Period34	110111	Period56		
001100		Period13	100010	Period35	111000	Period57		
001101		Period14	100011	Period36	111001	Period58		
001110		Period15	100100	Period37	111010	Period59		
001111		Period16	100101	Period38	111011	Period60		
010000		Period17	100110	Period39	111100	Period61		
010001		Period18	100111	Period40	111101	Period62		
010010		Period19	101000	Period41	111110	Period63		
010011		Period20	101001	Period42	111111	Period64		
010100	Period21	101010	Period43					
010101	Period22	101011	Period44					
Restriction								



7) R07H (DSLP): Deep Sleep Command

R07H	Bit										
Inst/Para	R/W	D/C/X	D7	D6	D5	D4	D3	D2	D1	D0	Code
DSLP	W	0	0	0	0	0	0	1	1	1	07H
1 st Parameter	W	1	1	0	1	0	0	1	0	1	A5h

NOTE: "-" Don't care, can be set to VDD or GND level

Description	<p>The command define as follows: After this command is transmitted, the chip would enter the deep-sleep mode to save power. The deep sleep mode would return to standby by hardware reset. The only one parameter is a check code, the command would be excited if check code = 0xA5.</p>
Restriction	This command only active when BUSY_N = "1".

8) R10H (DTM): Data Start transmission Register

R10H	Bit										
Inst/Para	R/W	D/C/X	D7	D6	D5	D4	D3	D2	D1	D0	Code
DTM	W	0	0	0	0	1	0	0	0	0	10H
2 bit mode	W	1									
1 st Parameter	W	1	Pixel1	Pixel2	Pixel3	Pixel4					00h
⋮	W	1	⋮	⋮	⋮	⋮	⋮	⋮	⋮	⋮	00h
M th Parameter	W	1	Pixel(n-3)	Pixel(n-2)	Pixel(n-1)	Pixel(n)					00h

NOTE: "-" Don't care, can be set to VDD or GND level

Description	<p>The command define as follows: The register is indicates that user start to transmit data, then write to SRAM. While data transmission complete, user must send command 12H. Then chip will start to send data/VCOM for panel.</p> <p>Pixel [1~n][1:0]: 2-bit/pixel</p> <table border="1"> <thead> <tr> <th>Image Data</th> <th colspan="2">DDX=1(default)</th> <th colspan="2">DDX=0</th> </tr> <tr> <th>Pixel[1:0]</th> <th>Gray level select</th> <th>IP output LUT select</th> <th>Gray level select</th> <th>IP output LUT select</th> </tr> </thead> <tbody> <tr> <td>00b</td> <td>Gray0</td> <td>ogray00</td> <td>Gray3</td> <td>ogray03</td> </tr> <tr> <td>01b</td> <td>Gray1</td> <td>ogray01</td> <td>Gray2</td> <td>ogray02</td> </tr> <tr> <td>10b</td> <td>Gray2</td> <td>ogray02</td> <td>Gray1</td> <td>ogray01</td> </tr> <tr> <td>11b</td> <td>Gray3</td> <td>ogray03</td> <td>Gray0</td> <td>ogray00</td> </tr> </tbody> </table> <p>Data mapping example: When DDX=1, Pixel[1:0]=01 -> Gray level select=Gray1, follow LUT data output from IP output port "ogray01". When DDX=0, Pixel[1:0]=11 -> Gray level select=Gray0, follow LUT data output from IP output port "ogray00".</p>	Image Data	DDX=1(default)		DDX=0		Pixel[1:0]	Gray level select	IP output LUT select	Gray level select	IP output LUT select	00b	Gray0	ogray00	Gray3	ogray03	01b	Gray1	ogray01	Gray2	ogray02	10b	Gray2	ogray02	Gray1	ogray01	11b	Gray3	ogray03	Gray0	ogray00
Image Data	DDX=1(default)		DDX=0																												
Pixel[1:0]	Gray level select	IP output LUT select	Gray level select	IP output LUT select																											
00b	Gray0	ogray00	Gray3	ogray03																											
01b	Gray1	ogray01	Gray2	ogray02																											
10b	Gray2	ogray02	Gray1	ogray01																											
11b	Gray3	ogray03	Gray0	ogray00																											
Restriction																															



9)R11H (DSP): Data Stop Command

R11H	Bit										
Inst/Para	R/W	D/CX	D7	D6	D5	D4	D3	D2	D1	D0	Code
DSP	W	0	0	0	0	1	0	0	0	1	11H
1 st Parameter	R	1	Data_flag	-	-	-	-	-	-	-	-

NOTE: "-" Don't care, can be set to VDD or GND level

Description	<p>-The command defines as :</p> <ul style="list-style-type: none"> While finished the data transmitting, user must send this command to driver and read Data_flag information. <p>1st Parameter:</p> <table border="1"> <thead> <tr> <th>Bit</th> <th>Name</th> <th>Description</th> </tr> </thead> <tbody> <tr> <td>7</td> <td>Data_flag</td> <td>0: Driver didn't receive all the data. 1: Driver has already received all of the one frame data.</td> </tr> </tbody> </table> <p>After "Data Start" (10h) or "Data Stop" (11h) commands and when data_flag=1, BUSY_N signal will become "0" and the refreshing of panel starts.</p>	Bit	Name	Description	7	Data_flag	0: Driver didn't receive all the data. 1: Driver has already received all of the one frame data.
Bit	Name	Description					
7	Data_flag	0: Driver didn't receive all the data. 1: Driver has already received all of the one frame data.					
Restriction	This command only actives when BUSY_N = "1".						

10)R12H (DRF): Display Refresh Command

R12H	Bit										
Inst/Para	R/W	D/CX	D7	D6	D5	D4	D3	D2	D1	D0	Code
DRF	W	0	0	0	0	1	0	0	1	0	12H
1 st Parameter	W	1	-	-	-	-	-	-	-	AC/DC VCOM	00h

NOTE: "-" Don't care, can be set to VDD or GND level

Description	<p>-The command defines as :</p> <p>While users send this command, driver will refresh display (data/VCOM) base on SRAM data and LUT.</p> <p>AC/DC VCOM:</p> <p>0: AC VCOM, VCOM will follow LUTC when updating image. (default) 1: DC VCOM, VCOM will always be VCOMDC when updating image</p> <p>After display refresh command, BUSY_N signal will become "0"</p>
Restriction	This command only actives when BUSY_N = "1"



11) R17H (AUTO): Auto Sequence

R17H	Bit										
Inst/Para	R/W	D/CX	D7	D6	D5	D4	D3	D2	D1	D0	Code
Auto Sequence	W	0	0	0	0	1	0	1	1	1	17H
1 st Parameter	W	1	Code[7]	Code[6]	Code[5]	Code[4]	Code[3]	Code[2]	Code[1]	Code[0]	A5h

Description	<p>The command can enable the internal sequence to execute several commands continuously. The successive execution can minimize idle time to avoid unnecessary power consumption and reduce the complexity of host's control procedure. The sequence contains several operations, including PON, DRF, POF, DSLP.</p> <p>AUTO (0x17) + Code(0xA5) = (PON→DRF→POF) AUTO (0x17) + Code(0xA7) = (PON→DRF→POF→DSLSP)</p>
Restriction	This command only actives when BUSY_N = "1".



12) R30H (PLL): PLL Control Register

R30H	Bit										
Inst/Para	R/W	D/CX	D7	D6	D5	D4	D3	D2	D1	D0	Code
PLL	W	0	0	0	1	1	0	0	0	0	30H
1 st Parameter	W	1	-	-	-	-	Dyna	FR[2]	FR[1]	FR[0]	02h

NOTE: "-" Don't care, can be set to VDD or GND level

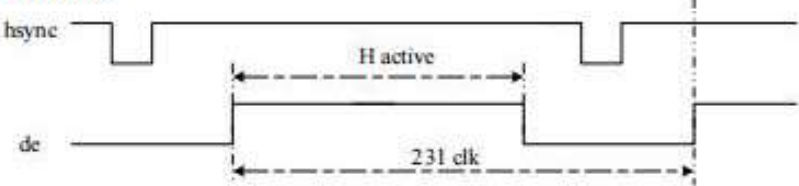
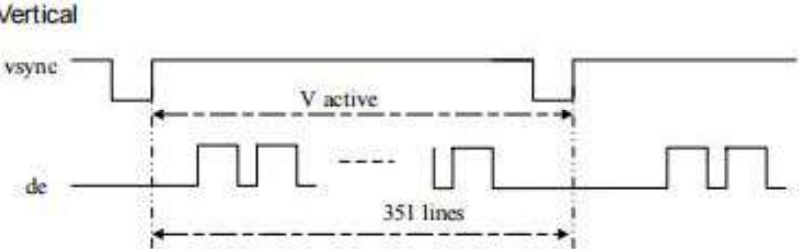
Description	<p>-The command defines as:</p> <p>The command controls the PLL clock frequency. The PLL structure must support the following frame rates:</p> <table border="1" data-bbox="699 629 1088 757"> <thead> <tr> <th>bit3</th> <th>Dynamic frame rate</th> </tr> </thead> <tbody> <tr> <td>0</td> <td>Disable (default)</td> </tr> <tr> <td>1</td> <td>Enable</td> </tr> </tbody> </table> <table border="1" data-bbox="699 786 1088 1151"> <thead> <tr> <th>FR[2:0]</th> <th>Frame rate</th> </tr> </thead> <tbody> <tr> <td>000</td> <td>12.5 Hz</td> </tr> <tr> <td>001</td> <td>25 Hz</td> </tr> <tr> <td>010</td> <td>50 Hz (default)</td> </tr> <tr> <td>011</td> <td>65 Hz</td> </tr> <tr> <td>100</td> <td>75 Hz</td> </tr> <tr> <td>101</td> <td>85 Hz</td> </tr> <tr> <td>110</td> <td>100 Hz</td> </tr> <tr> <td>111</td> <td>120 Hz</td> </tr> </tbody> </table>	bit3	Dynamic frame rate	0	Disable (default)	1	Enable	FR[2:0]	Frame rate	000	12.5 Hz	001	25 Hz	010	50 Hz (default)	011	65 Hz	100	75 Hz	101	85 Hz	110	100 Hz	111	120 Hz
bit3	Dynamic frame rate																								
0	Disable (default)																								
1	Enable																								
FR[2:0]	Frame rate																								
000	12.5 Hz																								
001	25 Hz																								
010	50 Hz (default)																								
011	65 Hz																								
100	75 Hz																								
101	85 Hz																								
110	100 Hz																								
111	120 Hz																								
remark	<p>-Horizontal</p>  <p>-Vertical</p> 																								
Restriction																									



13)R40H (TSC): Temperature Sensor Command

R40H		Bit									
Inst/Para	R/W	D/CX	D7	D6	D5	D4	D3	D2	D1	D0	Code
TSC	W	0	0	1	0	0	0	0	0	0	40H
1 st Parameter	R	1	D10/TS[7]	D9/TS[6]	D8/TS[5]	D7/TS[4]	D6/TS[3]	D5/TS[2]	D4/TS[1]	D3/TS[0]	-
2 nd Parameter	R	1	D2/TS[9]	D1/TS[8]	D0	-	-	-	-	-	-

NOTE: "-" Don't care, can be set to VDD or GND level

Description	<p>-The command define as follows: This command indicates the temperature value. If R41H(TSE) bit7 set to 0, this command reads internal temperature sensor value. If R41H(TSE) bit7 set to 1, this command reads external (LM75) temperature sensor value</p>																																																																																																																																																																										
	<table border="1"> <thead> <tr> <th>TS[7:0]/D[10:3]</th> <th>T (°C)</th> <th>TS[7:0]/D[10:3]</th> <th>T (°C)</th> <th>TS[7:0]/D[10:3]</th> <th>T (°C)</th> </tr> </thead> <tbody> <tr><td>11100111</td><td>-25</td><td>00000000</td><td>0</td><td>00011001</td><td>25</td></tr> <tr><td>11101000</td><td>-24</td><td>00000001</td><td>1</td><td>00011010</td><td>26</td></tr> <tr><td>11101001</td><td>-23</td><td>00000010</td><td>2</td><td>00011011</td><td>27</td></tr> <tr><td>11101010</td><td>-22</td><td>00000011</td><td>3</td><td>00011100</td><td>28</td></tr> <tr><td>11101011</td><td>-21</td><td>00000100</td><td>4</td><td>00011101</td><td>29</td></tr> <tr><td>11101100</td><td>-20</td><td>00000101</td><td>5</td><td>00011110</td><td>30</td></tr> <tr><td>11101101</td><td>-19</td><td>00000110</td><td>6</td><td>00011111</td><td>31</td></tr> <tr><td>11101110</td><td>-18</td><td>00000111</td><td>7</td><td>00100000</td><td>32</td></tr> <tr><td>11101111</td><td>-17</td><td>00001000</td><td>8</td><td>00100001</td><td>33</td></tr> <tr><td>11110000</td><td>-16</td><td>00001001</td><td>9</td><td>00100010</td><td>34</td></tr> <tr><td>11110001</td><td>-15</td><td>00001010</td><td>10</td><td>00100011</td><td>35</td></tr> <tr><td>11110010</td><td>-14</td><td>00001011</td><td>11</td><td>00100100</td><td>36</td></tr> <tr><td>11110011</td><td>-13</td><td>00001100</td><td>12</td><td>00100101</td><td>37</td></tr> <tr><td>11110100</td><td>-12</td><td>00001101</td><td>13</td><td>00100110</td><td>38</td></tr> <tr><td>11110101</td><td>-11</td><td>00001110</td><td>14</td><td>00100111</td><td>39</td></tr> <tr><td>11110110</td><td>-10</td><td>00001111</td><td>15</td><td>00101000</td><td>40</td></tr> <tr><td>11110111</td><td>-9</td><td>00010000</td><td>16</td><td>00101001</td><td>41</td></tr> <tr><td>11111000</td><td>-8</td><td>00010001</td><td>17</td><td>00101010</td><td>42</td></tr> <tr><td>11111001</td><td>-7</td><td>00010010</td><td>18</td><td>00101011</td><td>43</td></tr> <tr><td>11111010</td><td>-6</td><td>00010011</td><td>19</td><td>00101100</td><td>44</td></tr> <tr><td>11111011</td><td>-5</td><td>00010100</td><td>20</td><td>00101101</td><td>45</td></tr> <tr><td>11111100</td><td>-4</td><td>00010101</td><td>21</td><td>00101110</td><td>46</td></tr> <tr><td>11111101</td><td>-3</td><td>00010110</td><td>22</td><td>00101111</td><td>47</td></tr> <tr><td>11111110</td><td>-2</td><td>00010111</td><td>23</td><td>00110000</td><td>48</td></tr> <tr><td>11111111</td><td>-1</td><td>00011000</td><td>24</td><td>00110001</td><td>49</td></tr> </tbody> </table> <table border="1"> <thead> <tr> <th>TS[9:8]</th> <th>T (°C)</th> </tr> </thead> <tbody> <tr><td>00</td><td>+0</td></tr> <tr><td>01</td><td>+0.25</td></tr> <tr><td>10</td><td>+0.5</td></tr> <tr><td>11</td><td>+0.75</td></tr> </tbody> </table>						TS[7:0]/D[10:3]	T (°C)	TS[7:0]/D[10:3]	T (°C)	TS[7:0]/D[10:3]	T (°C)	11100111	-25	00000000	0	00011001	25	11101000	-24	00000001	1	00011010	26	11101001	-23	00000010	2	00011011	27	11101010	-22	00000011	3	00011100	28	11101011	-21	00000100	4	00011101	29	11101100	-20	00000101	5	00011110	30	11101101	-19	00000110	6	00011111	31	11101110	-18	00000111	7	00100000	32	11101111	-17	00001000	8	00100001	33	11110000	-16	00001001	9	00100010	34	11110001	-15	00001010	10	00100011	35	11110010	-14	00001011	11	00100100	36	11110011	-13	00001100	12	00100101	37	11110100	-12	00001101	13	00100110	38	11110101	-11	00001110	14	00100111	39	11110110	-10	00001111	15	00101000	40	11110111	-9	00010000	16	00101001	41	11111000	-8	00010001	17	00101010	42	11111001	-7	00010010	18	00101011	43	11111010	-6	00010011	19	00101100	44	11111011	-5	00010100	20	00101101	45	11111100	-4	00010101	21	00101110	46	11111101	-3	00010110	22	00101111	47	11111110	-2	00010111	23	00110000	48	11111111	-1	00011000	24	00110001	49	TS[9:8]	T (°C)	00	+0	01	+0.25	10	+0.5	11
TS[7:0]/D[10:3]	T (°C)	TS[7:0]/D[10:3]	T (°C)	TS[7:0]/D[10:3]	T (°C)																																																																																																																																																																						
11100111	-25	00000000	0	00011001	25																																																																																																																																																																						
11101000	-24	00000001	1	00011010	26																																																																																																																																																																						
11101001	-23	00000010	2	00011011	27																																																																																																																																																																						
11101010	-22	00000011	3	00011100	28																																																																																																																																																																						
11101011	-21	00000100	4	00011101	29																																																																																																																																																																						
11101100	-20	00000101	5	00011110	30																																																																																																																																																																						
11101101	-19	00000110	6	00011111	31																																																																																																																																																																						
11101110	-18	00000111	7	00100000	32																																																																																																																																																																						
11101111	-17	00001000	8	00100001	33																																																																																																																																																																						
11110000	-16	00001001	9	00100010	34																																																																																																																																																																						
11110001	-15	00001010	10	00100011	35																																																																																																																																																																						
11110010	-14	00001011	11	00100100	36																																																																																																																																																																						
11110011	-13	00001100	12	00100101	37																																																																																																																																																																						
11110100	-12	00001101	13	00100110	38																																																																																																																																																																						
11110101	-11	00001110	14	00100111	39																																																																																																																																																																						
11110110	-10	00001111	15	00101000	40																																																																																																																																																																						
11110111	-9	00010000	16	00101001	41																																																																																																																																																																						
11111000	-8	00010001	17	00101010	42																																																																																																																																																																						
11111001	-7	00010010	18	00101011	43																																																																																																																																																																						
11111010	-6	00010011	19	00101100	44																																																																																																																																																																						
11111011	-5	00010100	20	00101101	45																																																																																																																																																																						
11111100	-4	00010101	21	00101110	46																																																																																																																																																																						
11111101	-3	00010110	22	00101111	47																																																																																																																																																																						
11111110	-2	00010111	23	00110000	48																																																																																																																																																																						
11111111	-1	00011000	24	00110001	49																																																																																																																																																																						
TS[9:8]	T (°C)																																																																																																																																																																										
00	+0																																																																																																																																																																										
01	+0.25																																																																																																																																																																										
10	+0.5																																																																																																																																																																										
11	+0.75																																																																																																																																																																										
Restriction	This command only actives when BUSY_N = "1".																																																																																																																																																																										



14)R41H (TSE): Temperature Sensor Calibration Register

R41H	Bit										
Inst/Para	R/W	D/CX	D7	D6	D5	D4	D3	D2	D1	D0	Code
TSE	W	0	0	1	0	0	0	0	0	1	41H
1 st Parameter	W	1	TSE	-	-	TO[4]	TO[3]	TO[2]	TO[1]	TO[0]	00h

NOTE: "-" Don't care, can be set to VDD or GND level

Description	-The command defines as: This command indicates the driver IC temperature sensor enable and calibration function. Reserve one temperature offset TO[3:0] for calibration 1. TO[3]: mean '+' or '-', while 0 is '+'; 1 is '-' 2. TO[2:0]: mean temperature offset value	
	Bit	Description
	3-0	TO[3:0] Temperature level: 0000: +0°C (default) 0001: +0.5°C 0010: +1°C 0011: +1.5°C 0100: +2°C 0101: +2.5°C 0110: +3°C 0111: +3.5°C 1000: -4°C 1001: -3.5°C 1010: -3°C 1011: -2.5°C 1100: -2°C 1101: -1.5°C 1110: -1°C 1111: -0.5°C
	4	TO[4] 0: +0.0°C (default) 1: +0.25°C
	7	TSE Internal temperature sensor enable 0: Internal temperature sensor enable.(default) 1: Internal temperature sensor disable, using external temperature sensor.
Restriction	This command only actives after R04H(PON)	



15)R42H (TSW): Temperature Sensor Write Register

R42H	Bit										
Inst/Para	R/W	D/CX	D7	D6	D5	D4	D3	D2	D1	D0	Code
TSW	W	0	0	1	0	0	0	0	1	0	42H
1 st Parameter	W	1	WATTR[7]	WATTR[6]	WATTR[5]	WATTR[4]	WATTR[3]	WATTR[2]	WATTR[1]	WATTR[0]	00h
2 nd Parameter	W	1	WMSB[7]	WMSB[6]	WMSB[5]	WMSB[4]	WMSB[3]	WMSB[2]	WMSB[1]	WMSB[0]	00h
3 rd Parameter	W	1	WLSB[7]	WLSB[6]	WLSB[5]	WLSB[4]	WLSB[3]	WLSB[2]	WLSB[1]	WLSB[0]	00h

NOTE: "-" Don't care, can be set to VDD or GND level

Description	-The command defines as:												
	This command writes the temperature.												
1 st Parameter:	1 st Parameter:												
	<table border="1"> <thead> <tr> <th>Bit</th> <th>Name</th> <th>Description</th> </tr> </thead> <tbody> <tr> <td>2-0</td> <td>WATTR[2:0]</td> <td>Pointer setting</td> </tr> <tr> <td>5-3</td> <td>WATTR[5:3]</td> <td>User-defined address bits (A2, A1, A0)</td> </tr> <tr> <td>7-6</td> <td>WATTR[7:6]</td> <td>I2C Write Byte Number 00: 1 byte (head byte only) 01: 2 bytes (head byte + pointer) 10: 3 bytes (head byte + pointer + 1st parameter) 11: 4 bytes (head byte + pointer + 1st parameter + 2nd parameter)</td> </tr> </tbody> </table>	Bit	Name	Description	2-0	WATTR[2:0]	Pointer setting	5-3	WATTR[5:3]	User-defined address bits (A2, A1, A0)	7-6	WATTR[7:6]	I2C Write Byte Number 00: 1 byte (head byte only) 01: 2 bytes (head byte + pointer) 10: 3 bytes (head byte + pointer + 1st parameter) 11: 4 bytes (head byte + pointer + 1st parameter + 2nd parameter)
Bit	Name	Description											
2-0	WATTR[2:0]	Pointer setting											
5-3	WATTR[5:3]	User-defined address bits (A2, A1, A0)											
7-6	WATTR[7:6]	I2C Write Byte Number 00: 1 byte (head byte only) 01: 2 bytes (head byte + pointer) 10: 3 bytes (head byte + pointer + 1st parameter) 11: 4 bytes (head byte + pointer + 1st parameter + 2nd parameter)											
2 nd Parameter:	2 nd Parameter:												
	<table border="1"> <thead> <tr> <th>Bit</th> <th>Name</th> <th>Description</th> </tr> </thead> <tbody> <tr> <td>7-0</td> <td>WMSB[7:0]</td> <td>MSByte of write-data to external temperature sensor</td> </tr> </tbody> </table>	Bit	Name	Description	7-0	WMSB[7:0]	MSByte of write-data to external temperature sensor						
Bit	Name	Description											
7-0	WMSB[7:0]	MSByte of write-data to external temperature sensor											
3 rd Parameter:	3 rd Parameter:												
	<table border="1"> <thead> <tr> <th>Bit</th> <th>Name</th> <th>Description</th> </tr> </thead> <tbody> <tr> <td>7-0</td> <td>WLSB[7:0]</td> <td>LSByte of write-data to external temperature sensor</td> </tr> </tbody> </table>	Bit	Name	Description	7-0	WLSB[7:0]	LSByte of write-data to external temperature sensor						
Bit	Name	Description											
7-0	WLSB[7:0]	LSByte of write-data to external temperature sensor											
Restriction	This command only actives after R04H(PON)												



16)R43H (TSR): Temperature Sensor Read Register

R43H	Bit										
Inst/Para	R/W	D/CX	D7	D6	D5	D4	D3	D2	D1	D0	Code
TSR	W	0	0	1	0	0	0	0	1	1	43H
1 st Parameter	R	1	RMSB[7]	RMSB[6]	RMSB[5]	RMSB[4]	RMSB[3]	RMSB[2]	RMSB[1]	RMSB[0]	-
2 nd Parameter	R	1	RLSB[7]	RLSB[6]	RLSB[5]	RLSB[4]	RLSB[3]	RLSB[2]	RLSB[1]	RLSB[0]	-

NOTE: "-" Don't care, can be set to VDD or GND level

Description	-The command defines as:						
	This command reads the temperature sensed by the temperature sensor. 1 st Parameter:						
	<table border="1"> <thead> <tr> <th>Bit</th> <th>Name</th> <th>Description</th> </tr> </thead> <tbody> <tr> <td>7-0</td> <td>RMSB[7:0]</td> <td>MSByte of read-data from external temperature sensor</td> </tr> </tbody> </table>	Bit	Name	Description	7-0	RMSB[7:0]	MSByte of read-data from external temperature sensor
Bit	Name	Description					
7-0	RMSB[7:0]	MSByte of read-data from external temperature sensor					
	2 nd Parameter:						
	<table border="1"> <thead> <tr> <th>Bit</th> <th>Name</th> <th>Description</th> </tr> </thead> <tbody> <tr> <td>7-0</td> <td>RLSB[7:0]</td> <td>LSByte of write-data from external temperature sensor</td> </tr> </tbody> </table>	Bit	Name	Description	7-0	RLSB[7:0]	LSByte of write-data from external temperature sensor
Bit	Name	Description					
7-0	RLSB[7:0]	LSByte of write-data from external temperature sensor					
Restriction	This command only activates after R04H(PON)						



17)R50H (CDI): VCOM and DATA interval setting Register

R50H	Bit										
Inst/Para	RW	D/CX	D7	D6	D5	D4	D3	D2	D1	D0	Code
CDI	W	0	0	1	0	1	0	0	0	0	50H
1 st Parameter	W	1	VBD[2]	VBD[1]	VBD[0]	DDX	CDI[3]	CDI[2]	CDI[1]	CDI[0]	97h

NOTE: "-" Don't care, can be set to VDD or GND level

Description

-The command defines as:
 This command can set 2 kinds of parameters, 1.VCOM to data output interval(CDI)
 :
CDI[3:0]: This command indicates the interval of VCOM and data output. When setting the vertical back porch, **the total blanking will be keep (55hsync)**.

Bit	Name	Description
3-0	CDI[3:0]	Vcom and data interval 0000: 17 hsync 0001: 16 hsync 0010: 15 hsync 0011: 14 hsync 0100: 13 hsync 0101: 12 hsync 0110: 11 hsync 0111: 10 hsync(default) 1000: 9 hsync 1001: 8 hsync 1010: 7 hsync 1011: 6 hsync 1100: 5 hsync 1101: 4 hsync 1110: 3 hsync 1111: 2 hsync

The timing diagram illustrates the relationship between internal signals and VCOM/data output. It shows internal vsync, hsync, and de signals. The VCOM output location is fixed, and the source data output follows. The CDI setting interval is shown as a red arrow, and the 55 hsync - CDI setting (fixed) period is indicated by a dashed line.



VBD[2:0]: Border data selection. (from LUT output by IP port border_w[1:0])

This register will make boarder pin output being mapped to a certain gray scale.

Bit 4	Bit7-5	Description	IP setting for Border LUT select
DDX	VBD[2:0]	Gray level	
0	000	Floating	N/A
	001	Gray3	border_buf=011
	010	Gray2	border_buf=010
	011	Gray1	border_buf=001
	100	Gray0	border_buf=000
1 (default)	000	Gray0	border_buf=000
	001	Gray1	border_buf=001
	010	Gray2	border_buf=010
	011	Gray3	border_buf=011
	100	Floating	N/A

Border output voltage level: The level selection is based on mapping LUT data.

Ex: Gray 1 waveform is mapping to 15V,without VCOM offset, the real output on Boarder pin shall be 15V.

Boarder output will follow FOPT definition being defined in R00h.

Restriction



18) R51H (LPD): Lower Power Detection Register

R51H	Bit										
Inst/Para	R/W	D/CX	D7	D6	D5	D4	D3	D2	D1	D0	Code
LPD	W	0	0	1	0	1	0	0	0	1	51H
1 st Parameter	R	1	-	-	-	-	-	-	-	LPD	-

NOTE: "-" Don't care, can be set to VDD or GND level

Description	<p>-The command defines as: This command indicates the input power condition. Host can read this data to understand the battery's condition. When LPD="1", system input power is normal. When LPD="0", system input power is lower (VDD<2.5v, which could be select in RE4H (LVSEL)).</p> <p>1st Parameter:</p> <table border="1"> <tr> <td>Bit 0</td> <td>LPD</td> </tr> <tr> <td>0</td> <td>Low power input.</td> </tr> <tr> <td>1</td> <td>Normal status.</td> </tr> </table>	Bit 0	LPD	0	Low power input.	1	Normal status.
Bit 0	LPD						
0	Low power input.						
1	Normal status.						
Restriction	This command only actives when BUSY_N = "1".						



19)R61H (TRES): Resolution setting

R61H	Bit										
Inst/Para	R/W	D/CX	D7	D6	D5	D4	D3	D2	D1	D0	Code
TRES	W	0	0	1	1	0	0	0	0	1	61H
1 st Parameter	W	1	-	-	-	-	-	-	HRES(9)	HRES(8)	00h
2 nd Parameter	W	1	HRES(7)	HRES(6)	HRES(5)	HRES(4)	HRES(3)	HRES(2)	0	0	00h
3 rd Parameter	W	1	-	-	-	-	-	-	VRES(9)	VRES(8)	00h
4 th Parameter	W	1	VRES(7)	VRES(6)	VRES(5)	VRES(4)	VRES(3)	VRES(2)	VRES(1)	VRES(0)	00h

NOTE: "-" Don't care, can be set to VDD or GND level

Description	<p>-The command define as follows: When using register: Horizontal display resolution(source) = HRES Vertical display resolution(gate) = VRES</p> <p>Note: No matter HRES[9:8],HRES[1:0],VRST[9] value being filled, it's always be 00b.</p> <p>Channel disable calculation: GD : First G active = G0; LAST active GD= first active +VRES[9:0] -1 SD : First active channel: =S0 ; LAST active SD= first active +HRES[9:2]*4-1</p> <p>EX :176X296 GD: First G active = G0 LAST active GD= 0+296-1= 295; (G295) SD : First active channel: =S0 LAST active SD=0+44*4-1=175; (S175)</p> <p>Note : Only supports source 176.ch for source 160ch. above</p>
Restriction	Horizontal resolution should be 4-multiple.



20) R65H(GSST): Gate/Source Start Setting Register

R65H	Bit										
Inst/Para	R/W	D/CX	D7	D6	D5	D4	D3	D2	D1	D0	Code
GSST	W	0	0	1	1	0	0	1	0	1	65H
1 st Parameter	W	1	-	-	-	-	-	-	S_start[9]	S_start[8]	00h
2 nd Parameter	W	1	S_start[7]	S_start[6]	S_start[5]	S_start[4]	S_start[3]	S_start[2]	0	0	00h
3 rd Parameter	W	1	-	-	-	-	-	-	G_start[9]	G_start[8]	00h
4 th Parameter	W	1	G_start[7]	G_start[6]	G_start[6]	G_start[4]	G_start[3]	G_start[2]	G_start[1]	G_start[0]	00h

NOTE: "-" Don't care, can be set to VDD or GND level

Description	-The command define as follows: Note: No matter S_start[9:8], S_start [1:0], VRST[9] value being filled, it's always be 00b. 1.S_Start [7:0] describe which source output line is the first date line 2.G_Start[8:0] describe which gate line is the first scan line
	Restriction S_Start should be the multiple of 4

21)R70H (REV): REVISION register

R70H	Bit										
Inst/Para	R/W	D/CX	D7	D6	D5	D4	D3	D2	D1	D0	Code
REV	W	0	0	1	1	1	0	0	0	0	70H
1 st Parameter	R	1	0	0	0	0	0	0	1	1	03h
2 nd Parameter	R	1	0	0	0	0	0	0	1	0	02h
3 rd Parameter	R	1	0	0	0	0	0	0	0	1	01h

NOTE: "-" Don't care, can be set to VDD or GND level

Description	-The command defines as: 1 st & 2 nd & 3 rd Parameter: <table border="1" style="margin-left: 20px;"> <thead> <tr> <th>Bit</th> <th>Description</th> </tr> </thead> <tbody> <tr> <td>7-0</td> <td>CHIP_REV</td> </tr> </tbody> </table>	Bit	Description	7-0	CHIP_REV
	Bit	Description			
7-0	CHIP_REV				
Restriction					



22)R80H (AMV): Auto Measure VCOM register

R80H	Bit										
Inst/Para	R/W	D/CX	D7	D6	D5	D4	D3	D2	D1	D0	Code
AMV	W	0	1	0	0	0	0	0	0	0	80H
1 st Parameter	W	1	P[1]	P[0]	AMVT[1]	AMVT[0]	XON	AMVS	AMV	AMVE	00h

NOTE: "-" Don't care, can be set to VDD or GND level

Description	<p>-The command defines as: This command indicates the IC status. Host can read this data to understand the IC status.</p> <p>1st Parameter:</p> <table border="1"> <thead> <tr> <th>Bit</th> <th>Name</th> <th>Description</th> </tr> </thead> <tbody> <tr> <td>0</td> <td>AMVE</td> <td>AMVE: Auto Measure Vcom Setting 0: Auto measure VCOM disable (default) 1: Auto measure VCOM enable</td> </tr> <tr> <td>1</td> <td>AMV</td> <td>AMV: Analog signal 0: Get Vcom value from R81h(default) 1: Get Vcom value in analog signal</td> </tr> <tr> <td>2</td> <td>AMVS</td> <td>AMVS: setting for Source output of AMV 0: Source output 0V during Auto Measure VCOM period. (default) 1: Source output VSPL_0 during Auto Measure VCOM period.</td> </tr> <tr> <td>3</td> <td>XON</td> <td>XON: setting for all Gate ON of AMV 0: Gate normally scan during Auto Measure VCOM period. (default) 1: All Gate ON during Auto Measure VCOM period.</td> </tr> <tr> <td>5-4</td> <td>AMVT[1:0]</td> <td>The sensing time of VCOM detection 00: 5s (default) 01: 10s 10: 15s 11: 20s</td> </tr> <tr> <td>7-6</td> <td>P[1:0]</td> <td>The sensing points of sampling time 00: 2 (default) 01: 4 10: 8 11: 16 Sampling time = the last quarter of sensing time (T) VCOM = average of N points. N=2,4,8,16</td> </tr> </tbody> </table>											Bit	Name	Description	0	AMVE	AMVE: Auto Measure Vcom Setting 0: Auto measure VCOM disable (default) 1: Auto measure VCOM enable	1	AMV	AMV: Analog signal 0: Get Vcom value from R81h(default) 1: Get Vcom value in analog signal	2	AMVS	AMVS: setting for Source output of AMV 0: Source output 0V during Auto Measure VCOM period. (default) 1: Source output VSPL_0 during Auto Measure VCOM period.	3	XON	XON: setting for all Gate ON of AMV 0: Gate normally scan during Auto Measure VCOM period. (default) 1: All Gate ON during Auto Measure VCOM period.	5-4	AMVT[1:0]	The sensing time of VCOM detection 00: 5s (default) 01: 10s 10: 15s 11: 20s	7-6	P[1:0]	The sensing points of sampling time 00: 2 (default) 01: 4 10: 8 11: 16 Sampling time = the last quarter of sensing time (T) VCOM = average of N points. N=2,4,8,16
	Bit	Name	Description																													
0	AMVE	AMVE: Auto Measure Vcom Setting 0: Auto measure VCOM disable (default) 1: Auto measure VCOM enable																														
1	AMV	AMV: Analog signal 0: Get Vcom value from R81h(default) 1: Get Vcom value in analog signal																														
2	AMVS	AMVS: setting for Source output of AMV 0: Source output 0V during Auto Measure VCOM period. (default) 1: Source output VSPL_0 during Auto Measure VCOM period.																														
3	XON	XON: setting for all Gate ON of AMV 0: Gate normally scan during Auto Measure VCOM period. (default) 1: All Gate ON during Auto Measure VCOM period.																														
5-4	AMVT[1:0]	The sensing time of VCOM detection 00: 5s (default) 01: 10s 10: 15s 11: 20s																														
7-6	P[1:0]	The sensing points of sampling time 00: 2 (default) 01: 4 10: 8 11: 16 Sampling time = the last quarter of sensing time (T) VCOM = average of N points. N=2,4,8,16																														
Restriction	<p>This command only actives when BUSY_N = "1".</p>																															

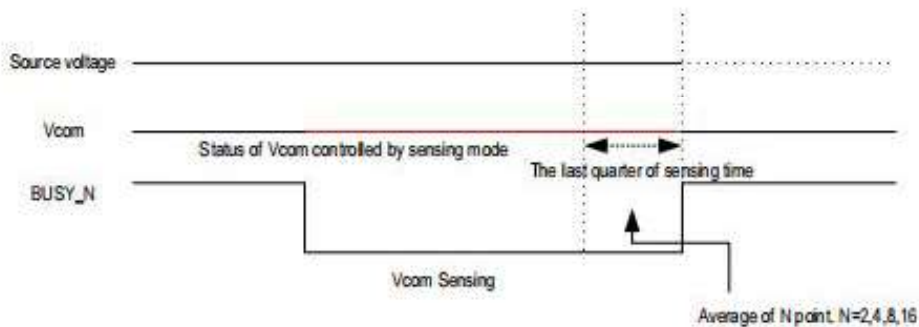



23)R81H (VV): VCOM Value register

R81H	Bit										
Inst/Para	R/W	D/C/X	D7	D6	D5	D4	D3	D2	D1	D0	Code
VV	W	0	1	0	0	0	0	0	0	1	81H
1 st Parameter	R	1	-	VV[6]	VV[5]	VV[4]	VV[3]	VV[2]	VV[1]	VV[0]	--

NOTE: "-" Don't care, can be set to VDD or GND level

Description	-The command defines as: This command could get the VCOM value										
	1 st Parameter:										
	Bit	Name	Description								
			VCOM value								
			VCOM[6:0]	Voltage(V)	VCOM[6:0]	Voltage(V)	VCOM[6:0]	Voltage(V)			
			0000000	00h 0	0011100	1Ch -1.4	0111000	38h -2.8			
			0000001	01h -0.05	0011101	1Dh -1.45	0111001	39h -2.85			
			0000010	02h -0.1	0011110	1Eh -1.5	0111010	3Ah -2.9			
			0000011	03h -0.15	0011111	1Fh -1.55	0111011	3Bh -2.95			
			0000100	04h -0.2	0100000	20h -1.6	0111100	3Ch -3			
			0000101	05h -0.25	0100001	21h -1.65	0111101	3Dh -3.05			
			0000110	06h -0.3	0100010	22h -1.7	0111110	3Eh -3.1			
			0000111	07h -0.35	0100011	23h -1.75	0111111	3Fh -3.15			
			0001000	08h -0.4	0100100	24h -1.8	1000000	40h -3.2			
			0001001	09h -0.45	0100101	25h -1.85	1000001	41h -3.25			
			0001010	0Ah -0.5	0100110	26h -1.9	1000010	42h -3.3			
			0001011	0Bh -0.55	0100111	27h -1.95	1000011	43h -3.35			
			0001100	0Ch -0.6	0101000	28h -2	1000100	44h -3.4			
	6-0	VV[6:0]	0001101	0Dh -0.65	0101001	29h -2.05	1000101	45h -3.45			
			0001110	0Eh -0.7	0101010	2Ah -2.1	1000110	46h -3.5			
			0001111	0Fh -0.75	0101011	2Bh -2.15	1000111	47h -3.55			
			0010000	10h -0.8	0101100	2Ch -2.2	1001000	48h -3.6			
			0010001	11h -0.85	0101101	2Dh -2.25	1001001	49h -3.65			
			0010010	12h -0.9	0101110	2Eh -2.3	1001010	4Ah -3.7			
			0010011	13h -0.95	0101111	2Fh -2.35	1001011	4Bh -3.75			
			0010100	14h -1	0110000	30h -2.4	1001100	4Ch -3.8			
			0010101	15h -1.05	0110001	31h -2.45	1001101	4Dh -3.85			
			0010110	16h -1.1	0110010	32h -2.5	1001110	4Eh -3.9			
			0010111	17h -1.15	0110011	33h -2.55	1001111	4Fh -3.95			
			0011000	18h -1.2	0110100	34h -2.6	1010000	50h -4			
			0011001	19h -1.25	0110101	35h -2.65	other	-4			
			0011010	1Ah -1.3	0110110	36h -2.7					
			0011011	1Bh -1.35	0110111	37h -2.75					
Restriction											



24)R82H (VDCS): VCOM_DC Setting Register

R82H	Bit										Code
Inst/Para	R/W	D/CX	D7	D6	D5	D4	D3	D2	D1	D0	
VDCS	W	0	1	0	0	0	0	0	1	0	82H
1 st Parameter	W	1	MTP_VCM	VDCS[6]	VDCS[5]	VDCS[4]	VDCS[3]	VDCS[2]	VDCS[1]	VDCS[0]	00h

NOTE: "-" Don't care, can be set to VDD or GND level

Description	-The command defines as: This command set the VCOM DC value. Driver will base on this value for VCM_DC.										
	1st Parameter:										
	Bit	Name	Description								

VCOM value										
VCOM[6:0]	Voltage(V)	VCOM[6:0]	Voltage(V)	VCOM[6:0]	Voltage(V)					
0000000	00h	0(default)	0011100	1Ch	-1.4	0111000	38h	-2.8		
0000001	01h	-0.05	0011101	1Dh	-1.45	0111001	39h	-2.85		
0000010	02h	-0.1	0011110	1Eh	-1.5	0111010	3Ah	-2.9		
0000011	03h	-0.15	0011111	1Fh	-1.55	0111011	3Bh	-2.95		
0000100	04h	-0.2	0100000	20h	-1.6	0111100	3Ch	-3		
0000101	05h	-0.25	0100001	21h	-1.65	0111101	3Dh	-3.05		
0000110	06h	-0.3	0100010	22h	-1.7	0111110	3Eh	-3.1		
0000111	07h	-0.35	0100011	23h	-1.75	0111111	3Fh	-3.15		
0001000	08h	-0.4	0100100	24h	-1.8	1000000	40h	-3.2		
0001001	09h	-0.45	0100101	25h	-1.85	1000001	41h	-3.25		
0001010	0Ah	-0.5	0100110	26h	-1.9	1000010	42h	-3.3		
0001011	0Bh	-0.55	0100111	27h	-1.95	1000011	43h	-3.35		
0001100	0Ch	-0.6	0101000	28h	-2	1000100	44h	-3.4		
0001101	0Dh	-0.65	0101001	29h	-2.05	1000101	45h	-3.45		
0001110	0Eh	-0.7	0101010	2Ah	-2.1	1000110	46h	-3.5		
0001111	0Fh	-0.75	0101011	2Bh	-2.15	1000111	47h	-3.55		
0010000	10h	-0.8	0101100	2Ch	-2.2	1001000	48h	-3.6		
0010001	11h	-0.85	0101101	2Dh	-2.25	1001001	49h	-3.65		
0010010	12h	-0.9	0101110	2Eh	-2.3	1001010	4Ah	-3.7		
0010011	13h	-0.95	0101111	2Fh	-2.35	1001011	4Bh	-3.75		
0010100	14h	-1	0110000	30h	-2.4	1001100	4Ch	-3.8		
0010101	15h	-1.05	0110001	31h	-2.45	1001101	4Dh	-3.85		
0010110	16h	-1.1	0110010	32h	-2.5	1001110	4Eh	-3.9		
0010111	17h	-1.15	0110011	33h	-2.55	1001111	4Fh	-3.95		
0011000	18h	-1.2	0110100	34h	-2.6	1010000	50h	-4		
0011001	19h	-1.25	0110101	35h	-2.65	other		-4		
0011010	1Ah	-1.3	0110110	36h	-2.7					
0011011	1Bh	-1.35	0110111	37h	-2.75					



	7	MTP_VCM	Follow MTP VCOM value in MTP mode 0: From the setting of MTP (default) 1: From the setting of register
Restriction			

25) R83H (PTL): Partial Window Register

R83H	Bit										
Inst/Para	R/W	D/CX	D7	D6	D5	D4	D3	D2	D1	D0	Code
PTL	W	0	1	0	0	0	0	0	1	1	83H
1 st Parameter	W	1	-	-	-	-	-	-	HRST[9]	HRST[8]	00h
2 nd Parameter	W	1	HRST[7]	HRST[6]	HRST[5]	HRST[4]	HRST[3]	HRST[2]	-	-	00h
3 rd Parameter	W	1	-	-	-	-	-	-	HRED[9]	HRED[8]	00h
4 th Parameter	W	1	HRED[7]	HRED[6]	HRED[5]	HRED[4]	HRED[3]	HRED[2]	-	-	00h
5 th Parameter	W	1	-	-	-	-	-	-	VRST[9]	VRST[8]	00h
6 th Parameter	W	1	VRST[7]	VRST[6]	VRST[5]	VRST[4]	VRST[3]	VRST[2]	VRST[1]	VRST[0]	00h
7 th Parameter	W	1	-	-	-	-	-	-	VRED[9]	VRED[8]	00h
8 th Parameter	W	1	VRED[7]	VRED[6]	VRED[5]	VRED[4]	VRED[3]	VRED[2]	VRED[1]	VRED[0]	00h
9 th Parameter	W	1	-	-	-	-	-	-	-	PMODE	00h

NOTE: "-" Don't care, can be set to VDD or GND level

Description	-This command sets partial window.												
	<table border="1"> <thead> <tr> <th>Name</th> <th>Description</th> </tr> </thead> <tbody> <tr> <td>HRST[9:2]</td> <td>Horizontal start address</td> </tr> <tr> <td>HRED[9:2]</td> <td>Horizontal end address. HRED must be greater than HRST.</td> </tr> <tr> <td>VRST[9:0]</td> <td>Vertical start address.</td> </tr> <tr> <td>VRED[9:0]</td> <td>Vertical end address. VRED must be greater than VRST.</td> </tr> <tr> <td>PMODE</td> <td>0: disable partial mode(default) 1: enable partial mode</td> </tr> </tbody> </table> <p>Note: No matter HRST[1:0], HRST[9:8], HRED[9:8], VRST[9], VRED[9] value being filled, it's always be 00b. No matter HRED[1:0] value being filled, it's always be 11b.</p> <p>Gates scan both inside and outside of the partial window.</p>	Name	Description	HRST[9:2]	Horizontal start address	HRED[9:2]	Horizontal end address. HRED must be greater than HRST.	VRST[9:0]	Vertical start address.	VRED[9:0]	Vertical end address. VRED must be greater than VRST.	PMODE	0: disable partial mode(default) 1: enable partial mode
Name	Description												
HRST[9:2]	Horizontal start address												
HRED[9:2]	Horizontal end address. HRED must be greater than HRST.												
VRST[9:0]	Vertical start address.												
VRED[9:0]	Vertical end address. VRED must be greater than VRST.												
PMODE	0: disable partial mode(default) 1: enable partial mode												
Restriction													



26) R90H (PGM): Program Mode

R90H	Bit										
Inst/Para	R/W	D/CX	D7	D6	D5	D4	D3	D2	D1	D0	Code
PGM	W	0	1	0	0	1	0	0	0	0	90H

NOTE: "-" Don't care, can be set to VDD or GND level

Description	-The command define as follows: After this command is issued, the chip would enter the program mode. The mode would return to standby by hardware reset.
Restriction	

27)R91H (APG): Active Program

R91H	Bit										
Inst/Para	R/W	D/CX	D7	D6	D5	D4	D3	D2	D1	D0	Code
APG	W	0	1	0	0	1	0	0	0	1	91H

NOTE: "-" Don't care, can be set to VDD or GND level

Description	-The command define as follows: After this command is transmitted, the programming state machine would be activated.
Restriction	The BUSY flag would change state from 0 to 1 while the programming is completed.

28)R92H (RMTP): Read MTP Data

R92H	Bit										
Inst/Para	R/W	D/CX	D7	D6	D5	D4	D3	D2	D1	D0	Code
RMTP	W	0	1	0	0	1	0	0	1	0	92H
1 st Parameter	R	1	Dummy								-
2 nd Parameter	R	1	The data of address 0x000 in the MTP								-
3 rd Parameter	R	1	The data of address 0x001 in the MTP								-
4 th Parameter	R	1	:								-
5 th Parameter	R	1	The data of address (n-1) in the MTP								-
6 th ~(m-1) th Parameter	R	1								-
m th Parameter	R	1	The data of address (n) in the MTP								-

NOTE: "-" Don't care, can be set to VDD or GND level

Description	-The command define as follows: The command is used for reading the content of MTP for checking the data of programming. The value of (n) is depending on the amount of programmed data, the max address = 0x17FF
-------------	---

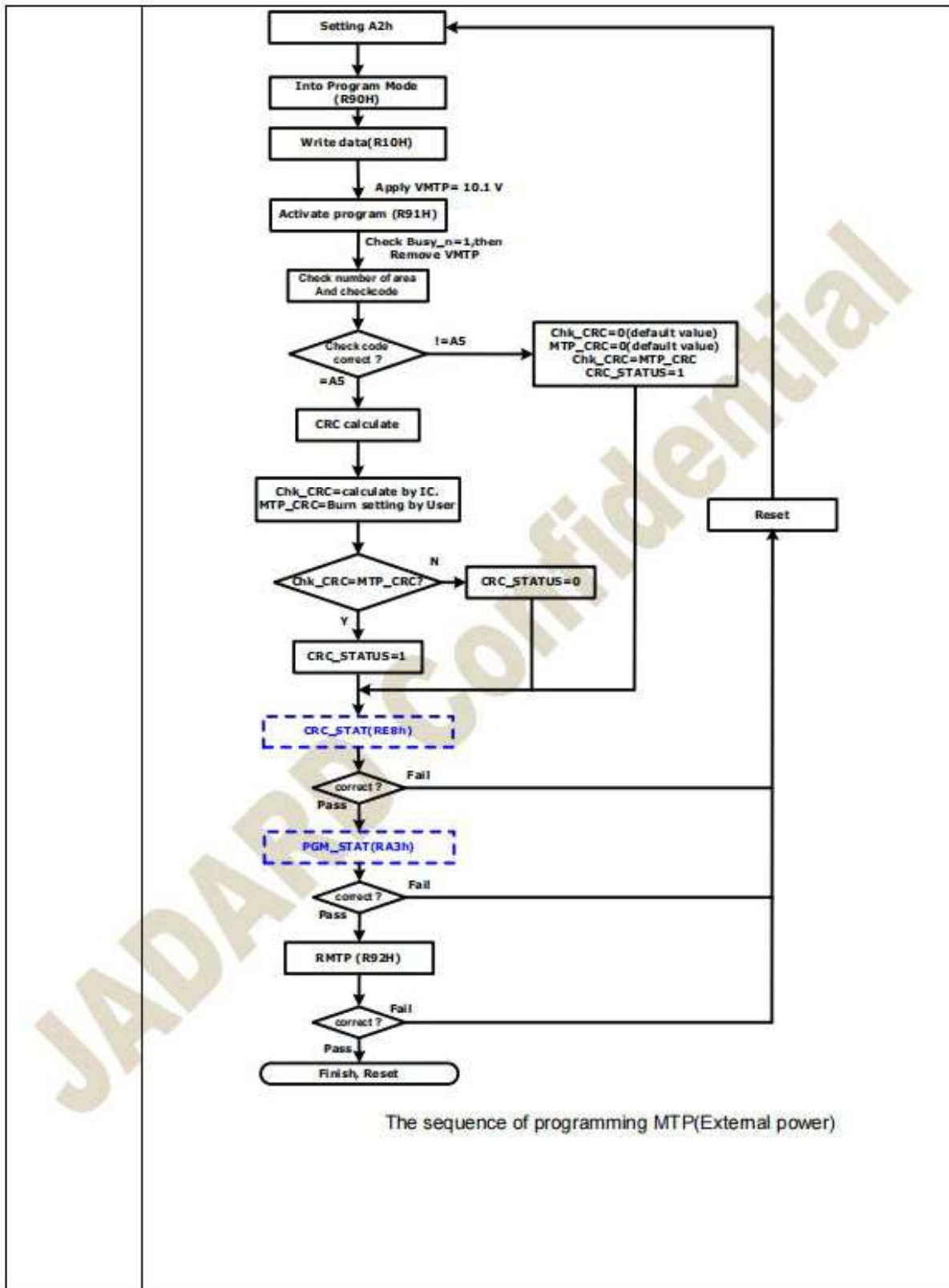

The sequence of programming MTP(External power)

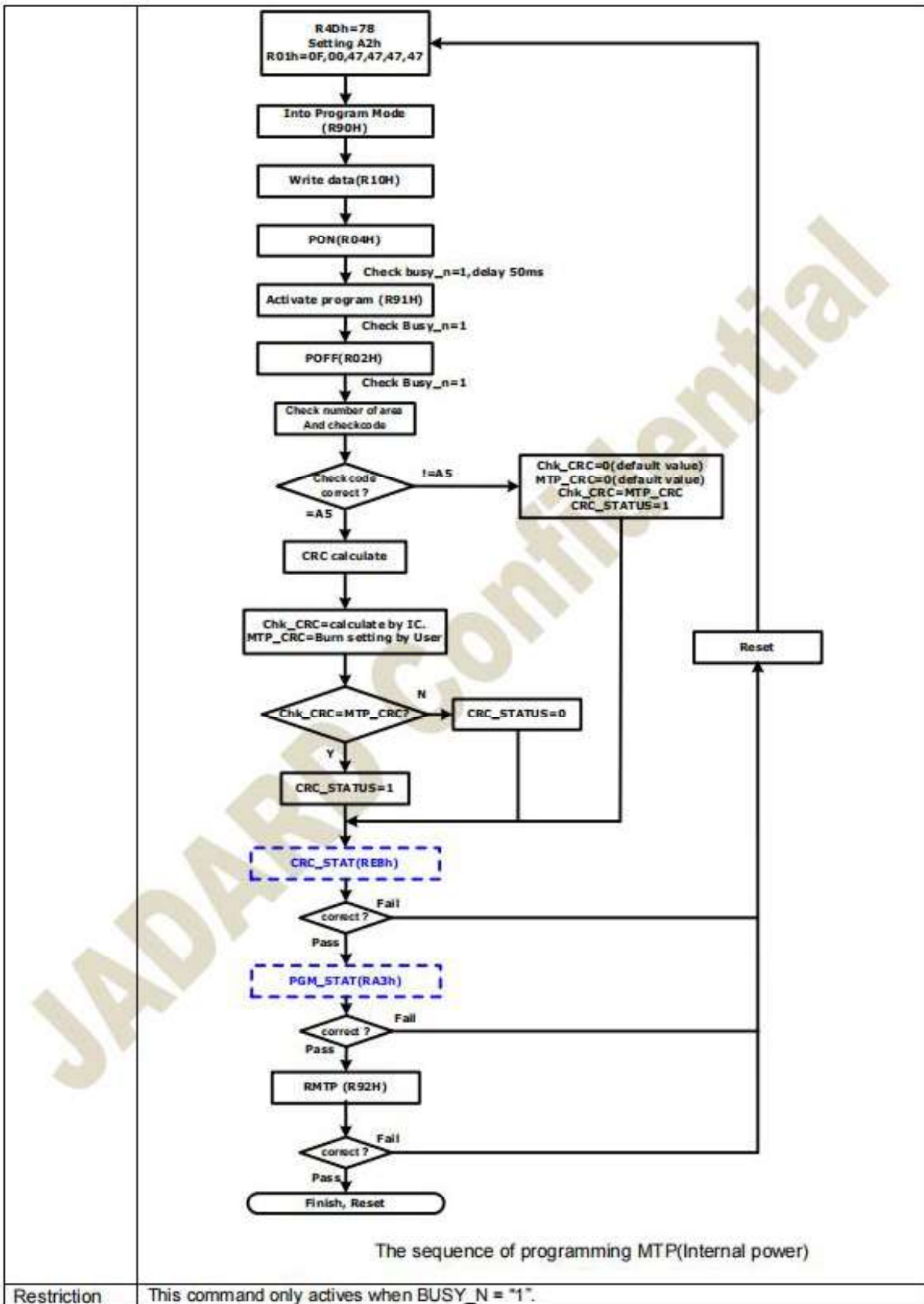



29)R9EH(REV2): REVISION2 register

R9EH	Bit										
Inst/Para	R/W	D/CX	D7	D6	D5	D4	D3	D2	D1	D0	Code
REV2	W	0	1	0	0	1	1	1	1	0	9EH
1 st Parameter	R	1	0	0	0	0	0	0	0	1	01h

Description	-The command defines as:										
	1 st Parameter:										
	Bit		Description								
	7-0		CHIP_REV								
Restriction											

30) R9FH(RMRB) Read MTP Reserved Bytes

R9FH	Bit										
Inst/Para	R/W	D/CX	D7	D6	D5	D4	D3	D2	D1	D0	Code
RMRB	W	0	1	0	0	1	1	1	1	1	9FH
1 st Parameter	R	1	Dummy								00h
2 nd Parameter	R	1	The data of address 0x16F7 in the MTP								00h
3 rd Parameter	R	1	:								00h
:	R	1	:								00h
97 th Parameter	R	1	:								00h
98 th Parameter	R	1	:								00h
101 th Parameter	R	1	The data of address 0x175A in the MTP								00h

Description	-The command define as follows:										
	The command is used for reading the content of MTP Reserved Byte for checking the data of programming.										
	This command could read these information from MTP directly.										
Restriction											



31) RE3H (PWS): Power Saving Register

RE3H	Bit										
Inst/Para	R/W	D/C/X	D7	D6	D5	D4	D3	D2	D1	D0	Code
PWS	W	0	1	1	1	0	0	0	1	1	E3H
1 st Parameter	W	1	VCOM_W[3:0]				SD_W[3:0]				00h

NOTE: "-" Don't care, can be set to VDD or GND level

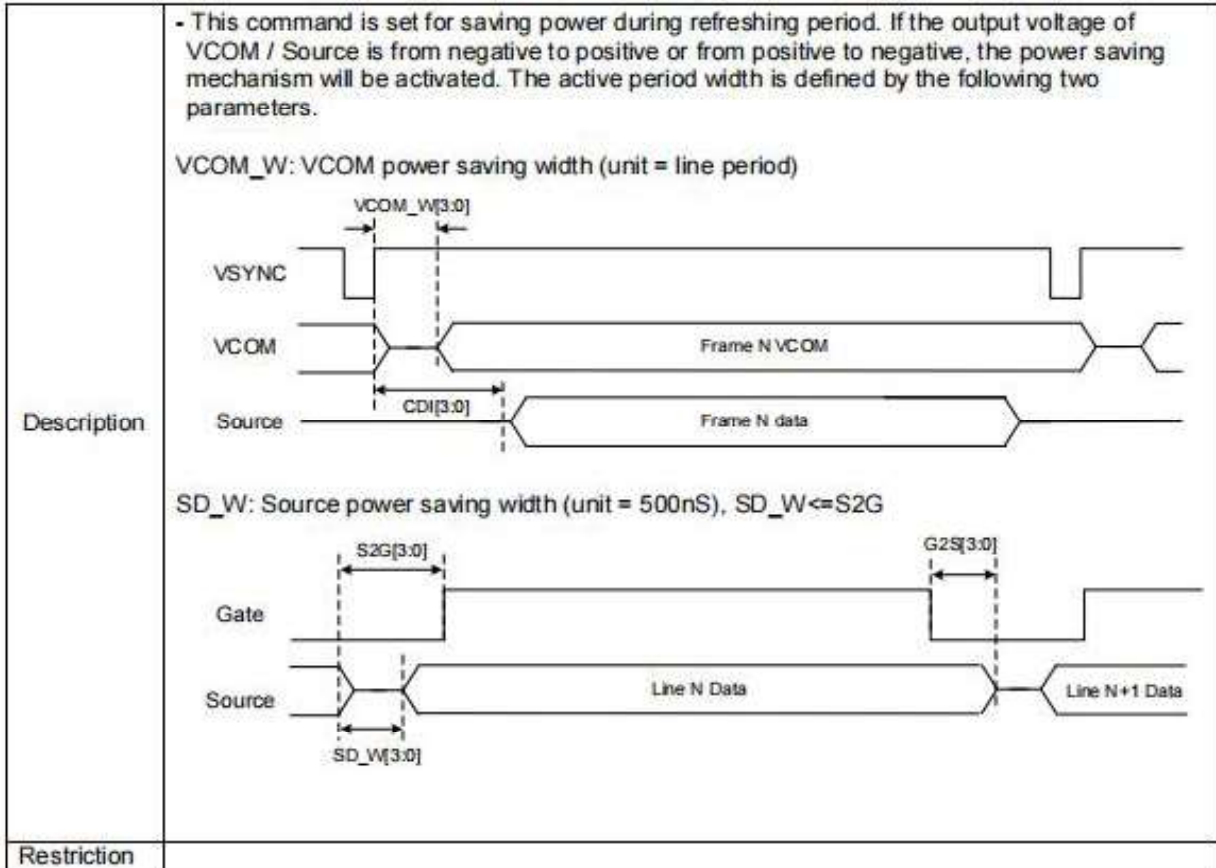

32) RE4H (LVSEL): LVD Voltage Select Register

RE4H	Bit										
Inst/Para	R/W	D/C/X	D7	D6	D5	D4	D3	D2	D1	D0	Code
LVSEL	W	0	1	1	1	0	0	1	0	0	E4H
1 st Parameter	W	1	-	-	-	-	-	-	LVD_SEL[1:0]		03h

NOTE: "-" Don't care, can be set to VDD or GND level

Description	LVD_SEL[1:0]: Low Power Voltage Selection	
	LVD_SEL[1:0]	LVD value
	00	< 2.2 V
	01	< 2.3 V
	10	< 2.4 V
	11	< 2.5 V (default)
Restriction		



8. Block Diagram

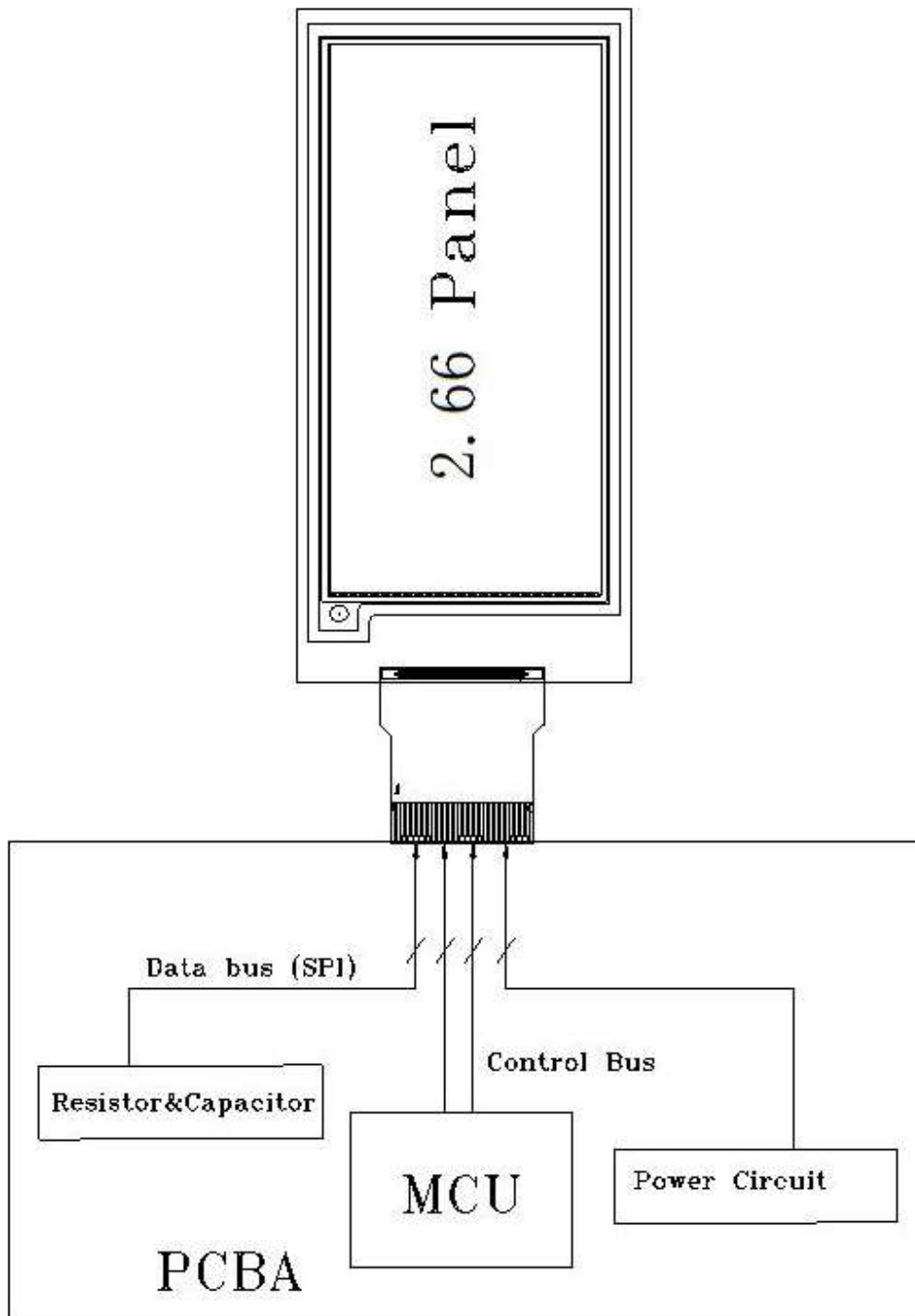



9. Typical Application Circuit with SPI Interface

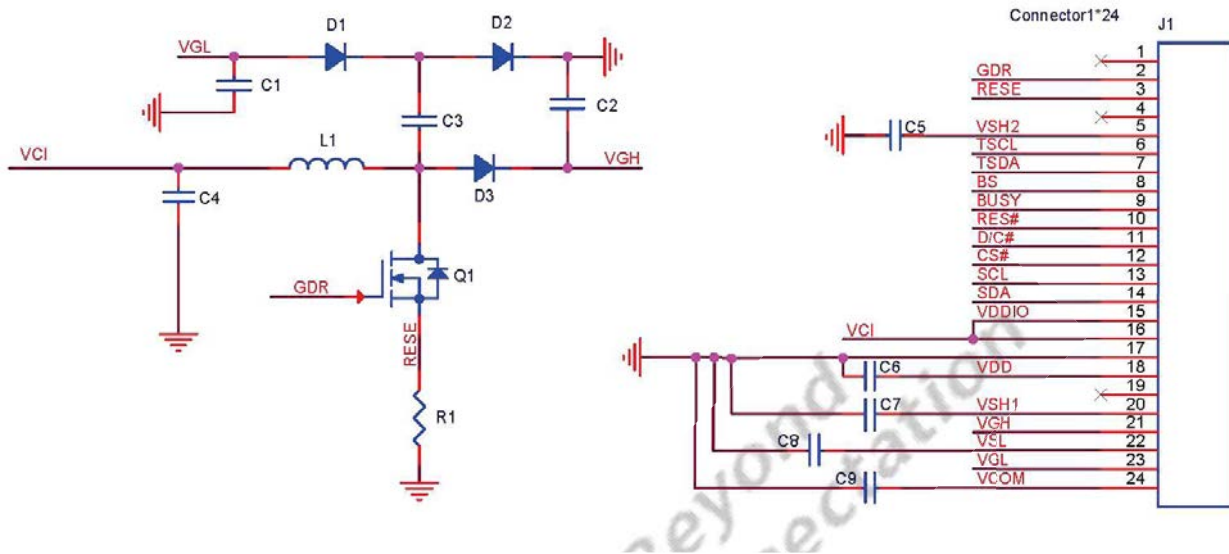

Part Name	Value	Reference Part
C1 C4 C5 C6 C7C8C9	1uF	Voltage Rating:25v
C2 C3	1uF	Voltage Rating:50v
R1	2.2Ω	0603, +/-1% variation
D1 D2 D3	Diode	MBR0530
Q1	NMOS	Si1308EDL、Si1304BDL
L1	47UH	CDRH2D18/LDNP-470NC

10 Typical Operating Sequence

10.1 LUT from OTP Operation Flow

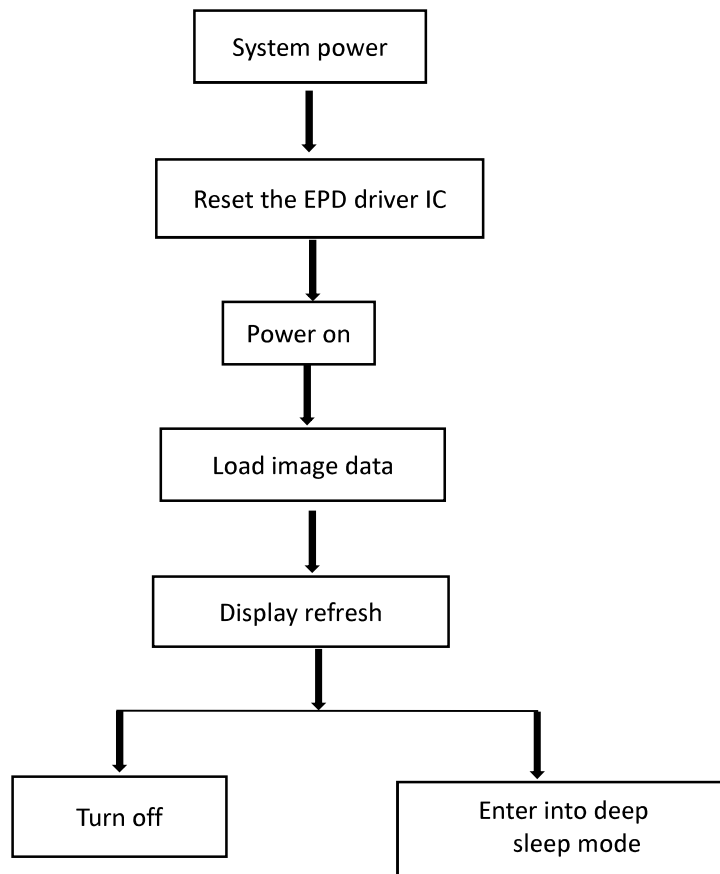



10.2 OTP Operation Reference Program Code

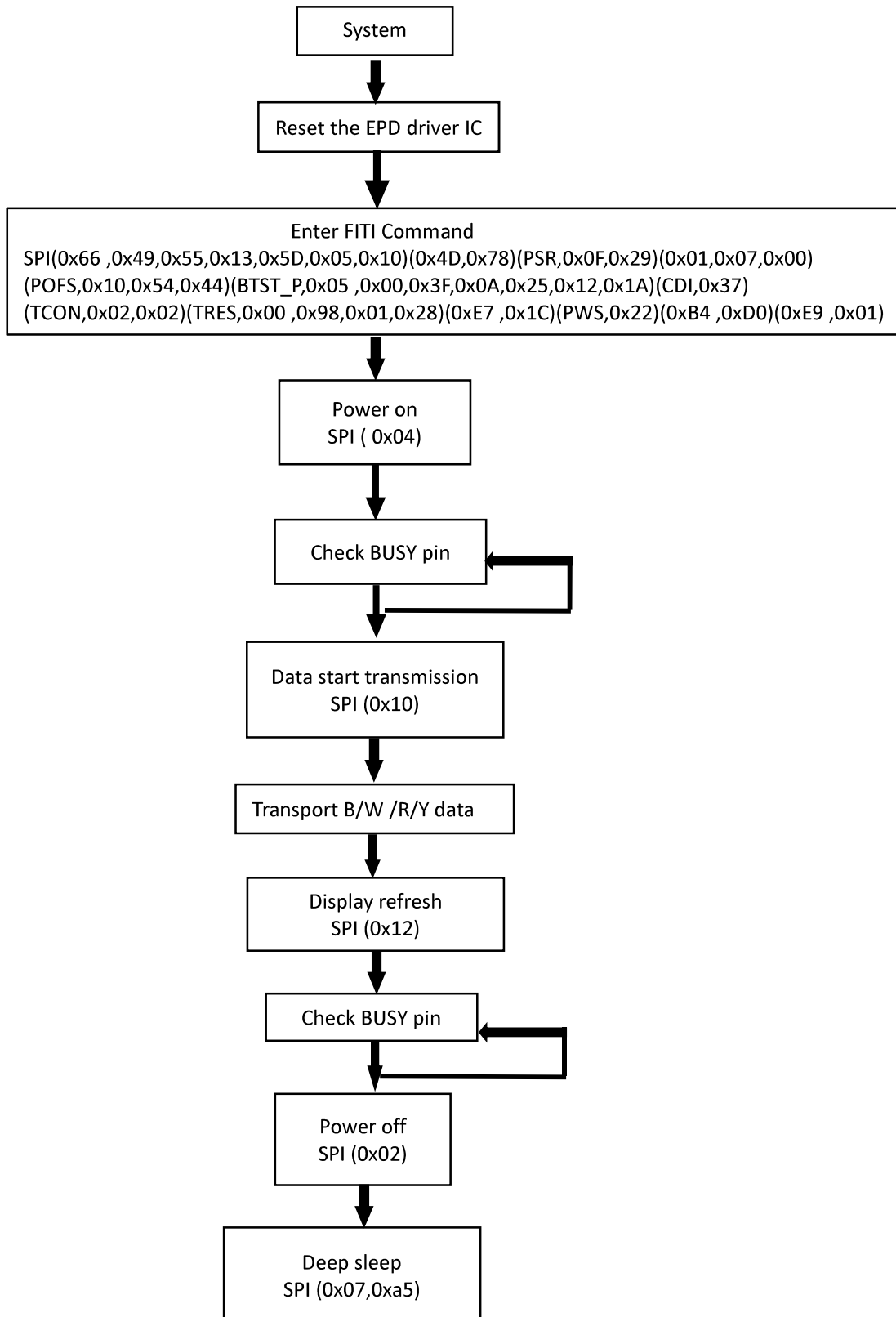



11. Reliability Test

TBD



12. Quality Assurance

12.1 Environment

Temperature: 23±2°C
Humidity: 55±10%RH

12.2 Illuminance

Brightness: 1200~1500LUX; distance: 20-30CM; Angle: Relate 45° surround.

12.3 Inspect method

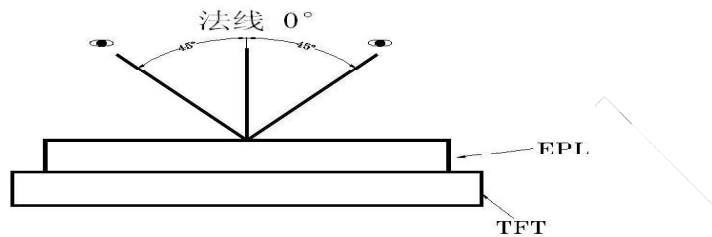

12.4 Display are

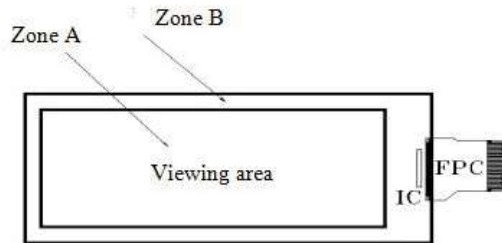

12.5 Ghosting test method

Three-color ghosting is measured with following transition from horizontal 4 scale pattern to vertical 4 scale pattern. The listed optical characteristics are only guaranteed under the controller & waveform provided by



- 1) Measurement Instruments: X-rite i1Pro
- 2) Ghosting formula:

W ghosting: $\Delta E = \text{Max} (\Delta E_{ab}(Y-W, R-W), \Delta E_{ab}(Y-W, W-W), \Delta E_{ab}(Y-W, B-W), \Delta E_{ab}(R-W, W-W), \Delta E_{ab}(R-W, B-W), \Delta E_{ab}(W-W, B-W))$

K ghosting: $\Delta E = \text{Max} (\Delta E_{ab}(Y-B, R-B), \Delta E_{ab}(Y-B, W-B), \Delta E_{ab}(Y-B, B-B), \Delta E_{ab}(R-B, W-B), \Delta E_{ab}(R-B, B-B), \Delta E_{ab}(W-B, B-B))$

R ghosting: $\Delta E = \text{Max} (\Delta E_{ab}(Y-R, R-R), \Delta E_{ab}(Y-R, W-R), \Delta E_{ab}(Y-R, B-R), \Delta E_{ab}(R-R, W-R), \Delta E_{ab}(R-R, B-R), \Delta E_{ab}(W-R, B-R))$

Y ghosting: $\Delta E = \text{Max} (\Delta E_{ab}(Y-Y, R-Y), \Delta E_{ab}(Y-Y, W-Y), \Delta E_{ab}(Y-Y, B-Y), \Delta E_{ab}(R-Y, W-Y), \Delta E_{ab}(R-Y, B-Y), \Delta E_{ab}(W-Y, B-Y))$





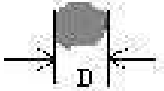
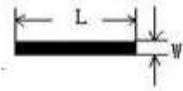

12.6 Inspection standard

12.6.1 Electric inspection standard

NO.	Item	Standard	Defect level	Method	Scope
1	Display	Clear display Display complete Display uniform	MA		
2	Black/White spots	 <p> $D \leq 0.25\text{mm}$, Allowed $0.25\text{mm} < D \leq 0.4\text{mm}$. $N \leq 4$ allowable $D > 0.4\text{mm}$ is not allowed </p>	MI	Visual inspection	Zone A
3	Black/White lines (No switch)	 <p> $L \leq 0.4\text{mm}, W \leq 0.1\text{mm}$ negligible $0.4\text{mm} < L \leq 1.0\text{mm}$ $0.1\text{mm} < W \leq 0.4\text{mm}$ $N \leq 4$ allowable $L > 1.0\text{mm}, W > 0.4\text{mm}$ is not allowed </p>			
4	Ghost image	Allowed in switching process	MI	Visual inspection	
5	Flash dot / Multilateral	Flash points are allowed when switching screens Multilateral colors outside the frame are allowed for fixed screen time	MI	Visual/ Inspection card	Zone A Zone B
6	Segmented display	Selection segments are all displayed, and other segments are not displayed after the selection segment.	MA	Visual inspection	Zone A
7	Short circuit/ Circuit break/ Abnormal Display	Not Allow			

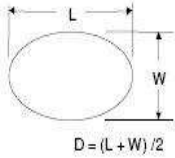
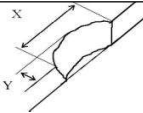
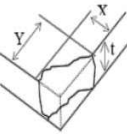
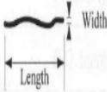

12.6.2 Appearance inspection standard

NO.	Item	Standard	Defect level	Method	Scope
1	B/W spots /Bubble/ Foreign bodies/ Dents	 $D = (L + W) / 2$ $D \leq 0.25\text{mm}$ negligible $0.25\text{mm} < D \leq 0.4\text{mm}$ $N \leq 4$ allowable $D > 0.4\text{mm}$ is not allowed	MI	Visual inspection	Zone A
2	Glass crack	Not Allow	MA	Visual / Microscope	Zone A Zone B
3	\Dirty	Allowed if can be removed	MI		Zone A Zone B
4	Chips/Scratch/ Edge crown	 $X \leq 3\text{mm}, Y \leq 0.5\text{mm}$ And without affecting the electrode is permissible  $2\text{mm} \leq X$ or $2\text{mm} \leq Y$ $t =$ not counted.and without affecting the electrode , permissible  $W \leq 0.1\text{mm}, L \leq 5\text{mm}$, without affecting the electrode , $n \leq 2$	MI	Visual / Microscope	Zone A Zone B
5	TFT Cracks	 Not Allow	MA	Visual / Microscope	Zone A Zone B
6	Dirty/ foreign body	Allowed if can be removed/ allow	MI	Visual / Microscope	Zone A / Zone B
7	FPC broken/ FPC oxidation / scratch	  Not Allow	MA	Visual / Microscope	Zone B

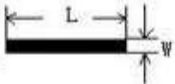
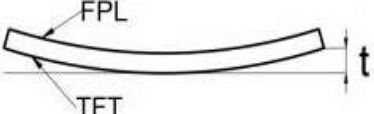

8	B/W Line	 <p> $L \leq 0.4\text{mm}, W \leq 0.1\text{mm}$ negligible $0.4\text{mm} < L \leq 1.0\text{mm}$ $0.1\text{mm} < W \leq 0.4\text{mm}$ $N \leq 4$ allowable $L > 1.0\text{mm}, W > 0.4\text{mm}$ is not allowed </p>	MI	Visual / Ruler	Zone B
9	TFT edge bulge /TFT chromatic aberration	<p>TFT edge bulge: $X \leq 3\text{mm}, Y \leq 0.3\text{mm}$ Allowed TFT chromatic aberration :Allowed</p>	MI	Visual / Microscope	Zone A Zone B
10	Electrostatic point	<p> $D \leq 0.2\text{mm}$, allow $0.2\text{mm} < D \leq 0.35\text{mm}$, $n \leq 4$ allow $D > 0.35\text{mm}$ is not allowed $(n \leq 5)$ items are allowed within 5 mm in diameter) </p>	MI	Visual / Microscope	Zone A
11	PCB damaged/ Poor welding/ Curl	<p>PCB (Circuit area) damaged Not Allow PCB Poor welding Not Allow PCB Curl $\leq 1\%$</p>	MI		
12	Edge glue height/ Edge glue bubble	<p>Edge Adhesives $H \leq \text{PS}$ surface (Including protect film) Edge adhesives seep in $\leq 1/2$ Margin width Length excluding Edge adhesives bubble: bubble Width $\leq 1/2$ Margin width; Length $\leq 5.0\text{mm}$. $n \leq 5$</p>	MI	Visual / Ruler	Zone B
13	Protect film	Surface scratch but not effect protect function, Allow	MI	Visual Inspection	
14	Silicon glue	<p>Thickness $\leq \text{PS}$ surface (With protect film): Full cover the IC; Shape: The width on the FPC $\leq 0.5\text{mm}$ (Front) The width on the FPC $\leq 1.0\text{mm}$ (Back) smooth surface, No obvious raised.</p>	MI	Visual Inspection	
15	Warp degree (TFT substrate)	 <p>$t \leq 1.0\text{mm}$</p>	MI	Ruler	
16	Color difference in COM area (Silver point area)	Allowed		Visual Inspection	



13.Packaging

<h1>EPD PACKING INSTRUCTION</h1>						DATE	
						DESIGN	
						CHECKED	
						APPROVED	

P/N	Customer Code	Ref. P/N	Type	PKG Method	Marking	Surface Marks	Pull Tape
0266			GLASS	Blister	BACK	None	YES

Packing Materials List					24PCS/LAYER, 20LAYER/CTN, TOTAL 480PCS/CTN.
List	Model	Materials	Q'ty	Unit	Pull tape:
Carton	7# 417*362*229 mm	corrugate	1	Piece	
Inner Carton	7#(INNER)400*343 *95 mm	corrugate	2	Piece	
Blister	0266I2	PET	22	Piece	
Thin foam	330.42*267.9*(1.5*1.8)MM	EPE	20	Piece	
Antistatic vacuum bag	450*590*0.075		2	Piece	
Foam board	2251-10	EPE	3	Piece	
PULL TAPE	20*7*TO.05		480	Piece	

Detail:

Blister box:

Note: there are 20 layers of products, divided into 2 inner boxes, and an empty blister box is placed on the top of each inner box, so the number of blister boxes is 22

QUANTITY: 24PCS

The blister box is rotated for placement

Empty blister
Thin foam
Blister
Foam board

Antistatic vacuum bag
Fixed with rubber bands

PUT IT INTO 7# INNER CARTON

INNER BOX LABEL

型号 (MODEL)	
数量 (QUANTITY)	
批号 (LOT#)	

PUT TWO 7# INNER CARTON INTO 7# CARTON

Packing belt

rohs Label

RoHS

Shipping marks according to customer's requirements

Epaper Identification	
QC:	PASS
Model No.	_____
Quantity	_____ pcs
Date:	_____
Carton No.	_____ of _____



14. Handling, Safety, and Environment Requirements

Warning

The display glass may break when it is dropped or bumped on a hard surface. Handle with care. Should the display break, do not touch the electrophoretic material. In case of contact with electrophoretic material, wash with water and soap.

Caution

The display module should not be exposed to harmful gases, such as acid and alkali gases, which corrode electronic components. Disassembling the display module.

Disassembling the display module can cause permanent damage and invalidates the warranty agreements.

Observe general precautions that are common to handling delicate electronic components. The glass can break and front surfaces can easily be damaged. Moreover the display is sensitive to static electricity and other rough environmental conditions.

Data sheet status	
Product specification	This data sheet contains final product specifications.
Limiting values	
Limiting values given are in accordance with the Absolute Maximum Rating System (IEC 134). Stress above one or more of the limiting values may cause permanent damage to the device. These are stress ratings only and operation of the device at these or at any other conditions above those given in the Characteristics sections of the specification is not implied. Exposure to limiting values for extended periods may affect device reliability.	
Application information	
Where application information is given, it is advisory and does not form part of the specification.	
Product Environmental certification	
ROHS	
REMARK	
All The specifications listed in this document are guaranteed for module only. Post-assembled operation or component(s) may impact module performance or cause unexpected effect or damage and therefore listed specifications is not warranted after any Post-assembled operation.	
Transport environment	
When the humidity of transportation environment is between 45%RH~70%RH, the product can be stored for 30 days, and the product can be stored for 10 days if it is lower or higher than this range	